

Operating Instructions Assembly Instructions

Worm gear screw jacks type 1 and type 2 SHE BG0,5 – BG 200.1 HSE 32 –HSE 140



1	Intended use	4
1.1	Screw jacks with safety devices for lifting platforms	4
1.2	Worm gear screw jacks in accordance with ATEX guideline 2014/34/EC.....	4
2	Accident prevention guide	5
3	Safety information	6
3.1	General safety information.....	6
3.2	ATEX safety information	6
3.3	Type plate	6
4	Technical specifications.....	7
4.1	High-performance worm gear screw jacks HSE, standard and with safety features.....	7
4.2	Worm gear screw jack SHE standards and with safety features.....	8
4.3	Technical specifications ATEX	9
5	Receipt of goods, storage, transport	10
5.1	Receipt of goods	10
5.2	Transport.....	10
5.3	Storage	10
6	Worm gear screw jacks, standard version	11
6.1	Safety worm gear screw jacks	11
	Safety nut (wear monitoring)	11
6.2	Safety nut (wear monitoring).....	12
6.3	Safety-trap nut (option for ball screw spindles).....	12
6.4	Options for screw jacks Ba1 and Ba2.....	12
7	Assembly.....	12
7.1	Fitting positions SHE.....	13
7.2	Fitting positions HSE.....	14
7.3	Pivot version.....	15
7.4	Assembly of the inductive limit switches	15
7.5	Assembly of electromechanical limit switches	16
7.6	Assembly of safety nut.....	16
7.7	Installing the nut breakage limit switch (Ba1).....	16
7.8	Installing the nut breakage limit switch (Ba2).....	17
7.9	Installing the pulse generator (rotational speed monitor).....	17
7.10	Mechanical fastening	18
7.11	Screw tightening torques	19
8	Initial operation.....	19
9	Maintenance and inspection	20
9.1	Maintenance plans.....	20
9.2	Maintenance instructions	20
9.3	SHE with low-viscosity grease level in the lift gear box	22
10	Decommissioning	22
11	Lubricants	23
12	Einbauerklärung / Declaration of incorporation / Déclaration d'incorporation.....	24
13	EG-Konformitätserklärung EC-Declaration of Conformity Déclaration "CE" de Conformité.....	26



These operating instructions describe the Pfaff-silberblau worm gear screw jacks of the SHE and HSE series. Please refer to our order confirmation or worm gear screw jack compendium for details on the layout, design and permissible operating conditions for the drives. Always observe and follow these operating instructions when using the equipment. Read the operating instructions carefully before commissioning!
 Observe the safety instructions!
 Store document!

	Practical information
	Warning against a general hazard. Risk of injury due to neglect.
	Warning against electrical voltage. Severe risk of injury due to neglect.
	Information on the safety screw jacks
	Danger of explosion
	Important information for use in spaces with explosion hazards
	Important information
	Assembly and setting information
	Disposal

SHE	Worm gear screw jack
HSE	High-performance worm gear screw jack
Type 1 (Ba1)	Method of operation for type with lifting screw
Type 2 (Ba2)	Method of operation for type with rotating screw
Specifications	A = screw on housing cover side; B= screw on mounting surface side
Tr	Trapezoidal thread spindle
Ku	Ball screw spindle
S	Buttress thread screw
P	Screw pitch
DIN	German industry standards
EN	European norm
ISO	International standards
ID	Duty cycle in % / h

1 Intended use

Worm gear screw jacks are incomplete machines and are intended for installation in complete machines or for assembly with several machines into a system.

They are drive elements that are employed for converting rotational movement into longitudinal movement and for reducing speed or converting torque.

The drive systems may only be used for the designated purpose.

They may be used only under the application conditions specified in the operating instructions, in the technical documentation or in the order confirmation.



Operation outside the respective performance limitations / ambient conditions is not permitted.

Not suitable for use in explosive-atmosphere zones.

Not suitable for use in aggressive environments, if not constructed especially for these applications.

Modifications to the screw jacks as well as the attachment of additional devices are only permitted with our express and written authorisation.

Pay attention to the technical data and functional description!



If stated in the order confirmation, the worm gear screw jacks with corresponding additional supplementary equipment comply with the requirements of various standards and guidelines:

1.1 Screw jacks with safety devices for lifting platforms

in accordance with DIN EN 1570-1:2015-01; DIN EN 280:2014-02, DIN EN 1756, DIN EN 1493:2011-02

Screw jacks with safety devices such as limited pitch angle – safety nut, speed monitoring and/or wear monitoring are designed or constructed according to the requirements of the applicable standard –

DIN EN 1570-1:2015-01 - Lifting tables

DIN EN 280:2014-02 - Elevating work platforms

DIN EN 1493:2011-02 – Vehicle lifts

DIN 56950-1:2012-05 – Event technology technical installations –

designed for installation in machines in accordance with the applicable standards.

The manufacturer of the complete system checks that the product in combination with the complete machine is in conformity. The manufacturer of the complete system is responsible for conducting the risk assessment for the complete system. The information in our operating instructions must be integrated in the instructions for the complete machine.

Required prototype tests (experts' examinations) need to be carried out under the responsibility of the manufacturer of the complete machine.

1.2 Worm gear screw jacks in accordance with ATEX guideline 2014/34/EC

are suited as components (2014/34/EC item 1 (3) for installation in machines for use in explosive-atmosphere zones as indicated by the ATEX marking.

For the ignition source analysis, the ATEX checklist must be filled out completely and submitted (www.pfaff-silberblau.com).



The manufacturer of the complete system checks that the product in combination with the complete machine is ATEX conform, and is responsible for conducting the ignition source analysis for the complete system.

The information in our operating instructions must be integrated in the instructions for the complete machine.

The suitability of the ATEX components for use in the existing Ex zone must be checked or assessed in accordance with the ATEX marking, the order confirmation, conformity declaration and type plate.

1.2.1 Marking in accordance with RL 2014/34/EC

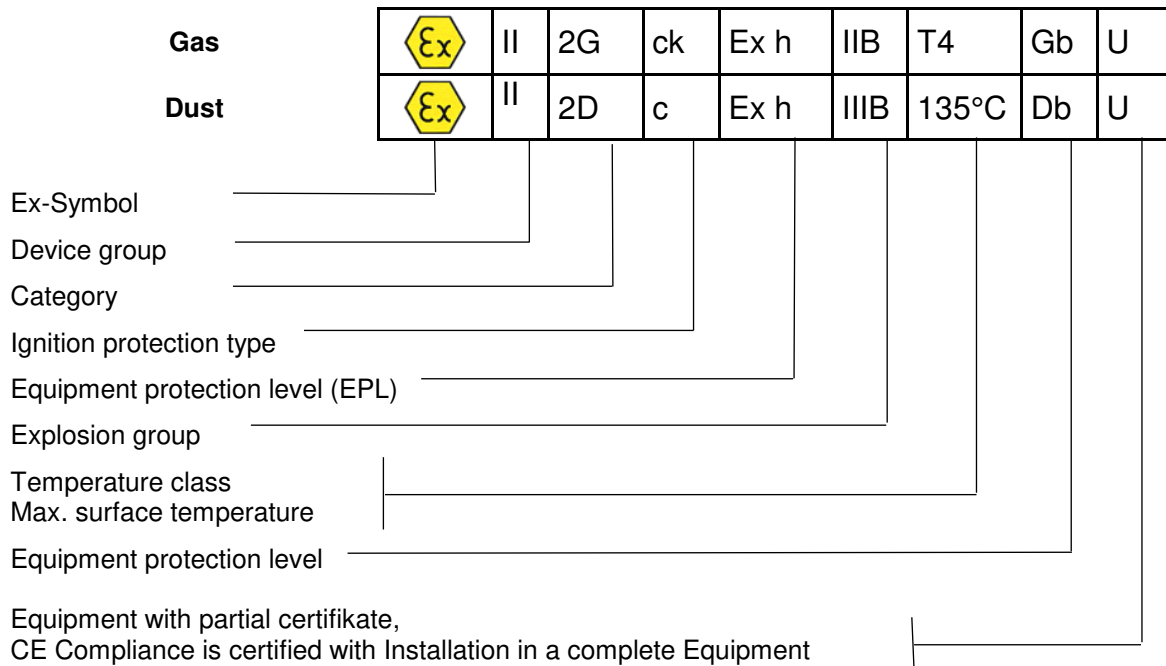

2 Accident prevention guide

Observe the relevant instructions, regulations, and standards in the country of use. In Germany, these are currently:

		Rules and regulations
EC machinery directive		2006/42/EC
Machine safety		DIN EN ISO 12100:2010
Lift devices		DIN EN 1494:2009-05
	Lifting tables	DIN EN 1570-1:2015-01
	Elevating work platforms	DIN EN 280:2014-02
	Loading platforms	DIN EN 1756
	Vehicle lifts	DIN EN 1493:2011-02
	Stages and studios	BGV C1
	Stage mechanics, safety equipment	DIN 56950-1:2012-05
	EC guideline; Equipment and protective systems in potentially explosive atmospheres (ATEX)	2014/34/EU
	EC guideline; Improving the safety and health protection in potentially explosive atmospheres	1999/92/EG (ATEX 137)
	Explosion protection basics and methodology	DIN EN 1127-1
	Non-electric devices for use in explosive-atmosphere zones - basics and requirements	DIN EN ISO 80079-36
	Non-electric devices for use in explosive-atmosphere zones - protection through constructional safety "c", ignition source monitoring "b"; liquid encapsulation "k"	DIN EN ISO 80079-37
	Explosive atmosphere	DIN EN 60079-0
	Explosive atmosphere, projection, selection and set-up of electrical systems	DIN EN 60079-14

3 Safety information

3.1 General safety information

Operation, installation and maintenance may only be carried out by qualified personnel. The responsible operator must be authorised in writing.



It is **forbidden** to transport people **or to stay in the danger area** of devices not designed for this purpose.

Exception: Screw jacks with safety features with corresponding intended use as described in Chapter 1.1 in the framework of the corresponding product standard.

Not suitable for use in explosive atmospheres!



Exception: Screw jacks are designed and marked as components for use in explosive-atmosphere zones, as described in Chapter 1.2

Never reach into moving parts. Cover them or cut off access to them.

Do not remove or disable the safety devices.

The operational and safety limit switches must ensure that the lifting process is safely stopped at the end positions.

To prevent contact with rotating/moving parts, attach protective covers (such as bellows, shaft caps) or make those areas of the machine inaccessible.



Screw/Travelling nut must be fastened on-site or be turn-secured or equipped with the optional torsional lock (max. screw torque according to technical documents). The construction must be able to bear the screw torque securely.

Ball thread spindles and multi-gear trapezoidal thread spindles are not self-locking. An appropriate brake device needs to be integrated into the system.

In the standard version, the screw does not have any protection against unintended skimming out of the gear box (Ba1) or against the travelling nut driving out the screw. A protection against skimming needs to be realised either on site or by worm gear screw jacks with mechanical end stops.

No lateral forces on the screw.

3.2 ATEX safety information

The owner of a system must ensure that the explosion-risk conditions are adhered to.

On-site layer thickness from surface coatings (e.g. lacquering) max. 2 mm (explosion group IIA and IIB) and 0.2 mm at explosion group IIC

Requirements for the reliable operation is a properly lubricated screw and a lift gear box provided with lubrication.

The affects from knocks and bumps on the screw jack is not permitted.

Dust deposits are to be removed regularly.



Connect the screw jacks with potential equalisation (earth) and check the bleeder resistance (<math><10^6\text{ Ohm}</math>).

Observe the speeds and permitted drive power output specified in the technical data when operating with rotation speed control in the potentially explosive atmospheres.

On motorized drives, monitor the motor output with output gauges or otherwise temperature monitors (e.g. thermistors (PTC) with evaluation device). Minimum requirements according to EN 13463-6 category 2-IPL2; cat. 3 –IPL1.

Materials used must be resistant against the media.

The operator must count or measure the load cycles or operating hours and document them.

3.3 Type plate

Type SHE 3.1N-2-1A-K/LFM-I-2785-T30x6-X			
Mat Nr.		Hub/∅	
Mat.-No	192034567	Lift	1000 mm
Ref-Nr	234567	Baujahr	
Ref.-No		Yr.of	2018
		Manuf.	

3.3.1 Design variants

In the stated variants, the first letter refers to the top side refers to the head side of the screw jack and the second letter refers to the opposite side.

K	Short lid
H	High lid
F	Guide ring
S/SR	Sheath tube
SA	Round sheath tube with stop collar
Sf	Sheath tube with guide ring
Si	Sheath tube with inductive limit switches
Sm	Sheath tube with mech. limit switches
Se	Sheath tube with mechanical end stop (protection against skimming)
SV	Reinforced rough sheath tube
V/VK	Torsional lock through Square sheath tube
Vi	Torsional lock with ind. limit switches
Vm	Torsional lock with mech. limit switches
Ve	Torsional lock with end stop
VP	Torsional lock by feather key
VV	Reinforced sheath tube
SFM-O	Short safety nut
SFM-K	Short safety nut in tube cap
SFM-L	Long safety nut
SFM-E	Long safety nut, el. monitored
SFM-D	Long safety nut, el. monitored with speed monitoring

Pivot lug version

P	swivelling version
P	swivelling version with end stop
Pm	swivelling version with mechanical operational limit switches
Pi	swivelling version with inductive operational limit switches
Q	swivelling version (bore head IV, rotated 90° to worm shaft)
Qe	swivelling version (bore head IV, rotated 90° to work shaft) with end stop
Qm	swivelling version (bore head IV, rotated 90° to work shaft) with mech. end stops
Qi	swivelling version (bore head IV, rotated 90° to work shaft) with mech. end stops

Travelling nut

LFM	Standard travelling nut
LSF	Travelling nut with spanner flat
LSA	Travelling nut with spherical contact surface
EFM	Single-flange nut (Tr or Ku)
LWZ	Travelling nut with swivel pin Combined with safety nut
-K	Short safety nut
-L	Long safety nut
-E	Long safety nut, el. monitored

4 Technical specifications

4.1 High-performance worm gear screw jacks HSE, standard and with safety features

Sizes in the HSE series		32	36.1	50.1	63.1	80.1	100.1	125.1	140	200.1
Max. lifting force	[kN]	5	10	25	50	100	200	350	500	1000
Max. tension	[kN]	5	10	25	50	100	178	350	500	1000
Spindle Tr ¹		18x6	24x5	40x8	50x9	60x12	70x12	100x16	120x16	160x20
Ratio N		4:1	5:1	6:1	7:1	8:1	8:1	10 2/3:1	10 2/3:1	13 1/3:1
Lift per rotation at ratio N	[mm/U]	1,0	1,0	1,33	1,28	1,5	1,5	1,5	1,5	1,5
Ratio L		16:1	20:1	24:1	28:1	32:1	32:1	32:1	32:1	40:1
Lift per rotation at ratio L	[mm/U]	0,25	0,25	0,33	0,32	0,375	0,375	0,5	0,5	0,5
Max. drive capacity ² at 20°C ambient temp. and 20% DC/h	[kW]	0,60	0,90	1,5	2,3	3,6	4,8	7,7	10,2	17,9
Max. drive capacity ² at 20°C ambient temperature and 10% DC/h	[kW]	1,0	1,5	2,6	4,0	6,3	8,4	13,5	17,9	31
Overall efficiency ratio N	[%]	See efficiency table compendium worm gear screw jack								
Overall efficiency ratio L	[%]	See efficiency table compendium worm gear screw jack								
Spindle efficiency	[%]	42,5	43	40	36,5	39,5	35,5	34	30	28,5
Torque-capacity-rotation speed at 20% ID/hr. and 20°C		See power table compendium on worm gear screw jacks								
Screw torque at max. lifting force	[Nm]	7,4	18,4	80	190	478	1060	2600	4235	11115
Max. permit. torque on the drive shaft	[Nm]	12,6	29,4	48,7	168	398	705	975	1640	4260
Max. permit. screw length at pressure load	[mm]	See offset diagram compendium worm gear screw jacks								

¹ Also with Ku screw

² Max. permissible values with BA 1 and Tr screw. Higher values are possible using BA 2 or Ku screws



4.2 Worm gear screw jack SHE standards and with safety features

Model series SHE unit size	BG	0,5	1.1	3.1	5.1	15.1	20.1
Max. lifting capacity dyn/stat	[kN]	5	10	30/45	50/75	100/150	200
Max. tensile load dyn/stat	[kN]	5	10	30/45	50/75	99	178/200
Screw Tr3		18x6	24x5	30x6	40x7	60x12	70x12
Ratio N		10:1	5:1	6:1	6:1	7 2/3:1	8:1
Lift per rotation at ratio N	[mm/U]	0,60	1,0	1,0	1,167	1,565	1,50
Ratio L		20:1	20:1	24:1	24:1	24:1	24:1
Lift per rotation at ratio L	[mm/U]	0,30	0,25	0,25	0,292	0,50	0,5
Max. drive capacity ⁴ at 20°C ambient temp. and 20% DC/h	[kW]	0,17	0,35	0,65	1,15	2,7	3,8
Max. drive capacity ² at 20°C ambient temperature and 10% DC/h	[kW]	0,25	0,55	0,9	1,65	3,85	5,4
Overall efficiency ratio N	[%]	31	29	27	24	27	24
Overall efficiency ratio L	[%]	24	20	19	16	17	17
Spindle efficiency	[%]	54	43	40	36,5	39,5	37,5
Torque-capacity-rotation speed at 20% ID/hr. and 20°C		See power table compendium on worm gear screw jacks					
Screw torque at max. lifting force	[Nm]	8,8	18,4	60	153	702	1009
Max. permit. torque on the drive shaft	[Nm]	12	29,4	46,5	92	195	280
Max. permit. screw length at pressure load	[mm]	See offset diagram compendium worm gear screw jacks					

Model series SHE unit size	BG	25	35	50.1	75	100.1	150	200.1
Max. lifting force	[kN]	250	350	500	750	800/1000	1500	2000
Max. tension	[kN]	250	350	500	750	800/1000	1500	-
Screw Tr1		90x16	100x16	120x16	140x20	160x20	190x24	220x28
Ratio N		10 2/3:1	10 2/3:1	10 2/3:1	12:1	12:1	19:1	17,5:1
Lift per rotation at ratio N	[mm/U]	1,50	1,50	1,50	1,667	1,667	1,263	1,60
Ratio L		32:1	32:1	32:1	36:1	36:1	-	
Lift per rotation at ratio L	[mm/U]	0,5	0,5	0,5	0,556	0,556	-	
Max. drive capacity ² at 20°C ambient temperature and 20% DC/h	[kW]	5,0	6,0	7,4	9,0	12,5	18,5	
Max. drive capacity ² at 20°C ambient temperature and 10% DC/h	[kW]	7,2	8,6	10,4	12,6	17,5	26	
Overall efficiency ratio N	[%]	22	21	15	18	15	15	
Overall efficiency ratio L	[%]	15	14	10	12	9	-	
Spindle efficiency	[%]	36,5	34	30	31,6	28,5	28,8	29
Torque-capacity-rotation speed at 20% ID/hr. and 20°C		See power table compendium on worm gear screw jacks						
Screw torque at max. lifting force	[Nm]	1725	2600	4235	7550	11115	19850	
Max. permit. torque on the drive shaft	[Nm]	480	705	840	2660	2660	4260	
Max. permit. screw length at pressure load	[mm]	See offset diagram compendium worm gear screw jacks						

³Also with Ku screw

⁴ Max. permissible values with BA 1 and Tr screw. Higher values are possible using BA 2 or Ku screws

4.3 Technical specifications ATEX



Worm gear screw jack for use in **spaces with explosion hazards** are designed based on the environmental influences (ATEX checklist) that have been given to us. The technical specifications and ATEX terms and conditions specified in the order confirmation must be adhered to. The manufacturer of the total system needs to evaluate the suitability according to the identification.



The declaration of conformity, in accordance with guideline 2014/34/EC, is rendered void if the technical data and ATEX conditions are not adhered to

4.3.1 Worm gear screw jacks SHE for explosive-atmosphere zones in acc. with 2014/34/EC (ATEX)

Model series SHE unit size	BG	1.1	3.1	5.1	15.1	20.1	25
Max. lifting capacity dyn/stat	[kN]	10	30/45	50/75	100/150	200	250
Max. tensile load dyn/stat	[kN]	10	30/45	50/75	99	178/200	250
Screw Tr5		24x5	30x6	40x7	60x12	70x12	90x16
Ratio N		5:1	6:1	6:1	7 2/3:1	8:1	10 2/3:1
Lift per rotation at ratio N	[mm/U]	1,0	1,0	1,167	1,565	1,50	1,50
Ratio L		20:1	24:1	24:1	24:1	24:1	32:1
Lift per rotation at ratio L	[mm/U]	0,25	0,25	0,292	0,50	0,5	0,5
Max. drive capacity at 20°C ambient temperature and 20% DC/h	[kW]	0,18	0,33	0,7	1,4	2,0	2,5
Max. drive capacity at 20°C ambient temperature and 10% DC/h	[kW]	0,35	0,65	1,15	2,7	3,8	5,0
Overall efficiency ratio N	[%]	29	27	24	27	24	22
Overall efficiency ratio L	[%]	20	19	16	17	17	15
Spindle efficiency	[%]	43	40	36,5	39,5	37,5	36,5
Torque-capacity-speed at 20% DC/h and 20°C		See power table compendium on worm gear screw jacks					
Screw torque at max. lifting force	[Nm]	18,4	60	153	702	1009	1725
Max. permit. torque on the drive shaft	[Nm]	29,4	46,5	92	195	280	480
Max. permit. screw length at pressure load	[mm]	See offset diagram compendium worm gear screw jacks					

Model series SHE unit size	BG	35	50.1	75	100.1	150.1	200.1
Max. lifting force	[kN]	350	500	750	800/1000	1500	2000
Max. tension	[kN]	350	500	750	800/1000	1500	-
Screw Tr		100x16	120x16	140x20	160x20	190x24	220x28
Ratio N		10 2/3:1	10 2/3:1	12:1	12:1	19:1	17,5:1
Lift per rotation at ratio N	[mm/U]	1,50	1,50	1,667	1,667	1,263	1,60
Ratio L		32:1	32:1	36:1	36:1	-	
Lift per rotation at ratio L	[mm/U]	0,5	0,5	0,556	0,556	-	
Max. drive capacity at 20°C ambient temperature and 20% DC/h	[kW]	3,0	3,8	4,5	6,5	9,5	
Max. drive capacity at 20°C ambient temperature and 10% DC/h	[kW]	6,0	7,4	9,0	12,5	18,5	
Overall efficiency ratio N	[%]	21	15	18	15	15	
Overall efficiency ratio L	[%]	14	10	12	9	-	
Spindle efficiency	[%]	34	30	31,6	28,5	28,8	29
Torque-capacity-speed at 20% DC/h and 20°C		See power table compendium on worm gear screw jacks					
Screw torque at max. lifting force	[Nm]	2600	4235	7550	11115	19850	
Max. permit. torque on the drive shaft	[Nm]	705	840	2660	2660	4260	
Max. permit. screw length at pressure load	[mm]	See offset diagram compendium worm gear screw jacks					

4.3.2 HSE for explosive-atmosphere zones in acc. with 2014/34/EC (ATEX)

Model series HSE unit size		36.1	50.1	63.1	80.1	100.1	125.1	140	200.1
Max. lifting force	[kN]	10	25	50	100	200	350	500	1000
Max. tension	[kN]	10	25	50	100	178	350	500	1000
Screw Tr6		24x5	40x8	50x9	60x12	70x12	100x16	120x16	160x20
Ratio N		5:1	6:1	7:1	8:1	8:1	10 2/3:1	10 2/3:1	13 1/3:1
Lift per rotation at ratio N	[mm/U]	1,0	1,33	1,28	1,5	1,5	1,5	1,5	1,5
Ratio L		20:1	24:1	28:1	32:1	32:1	32:1	32:1	40:1
Lift per rotation at ratio L	[mm/U]	0,25	0,33	0,32	0,375	0,375	0,5	0,5	0,5
Max. drive capacity at 20°C ambient temperature and 20% DC/h	[kW]	0,45	0,75	1,2	1,8	2,4	3,8	5,5	9
Max. drive capacity at 20°C ambient temperature and 10% DC/h	[kW]	0,9	1,5	2,3	3,6	4,8	7,7	10,2	17,9
Overall efficiency ratio N	[%]	See efficiency table compendium worm gear screw jack							
Overall efficiency ratio L	[%]	See efficiency table compendium worm gear screw jack							
Spindle efficiency	[%]	43	40	36,5	39,5	35,5	34	30	28,5
Torque-capacity-rotation speed at 20% ID/hr. and 20°C		See power table compendium on worm gear screw jacks							
Screw torque at max. lifting force	[Nm]	18,4	80	190	478	1060	2600	4235	11115
Max. permit. torque on the drive shaft	[Nm]	29,4	48,7	168	398	705	975	1640	4260
Max. permit. screw length at pressure load	[mm]	See offset diagram compendium worm gear screw jacks							

5 Receipt of goods, storage, transport

5.1 Receipt of goods



Startup with defective screw jacks is forbidden.



Immediately check if the contents of delivery correspond with the shipping documents upon receipt. No other warranties can be approved for subsequent defect claims.

Claims on defects and incompleteness are to be made immediately at Pfaff-silberblau.

Claims on perceivable damages due to transport are to be reported to the transport company immediately.



Small parts such as limit switches are usually delivered unattached and packed individually.

5.2 Transport



Lift / transport the screw jack by the appropriate hoisting points.

Pay attention to the attachment parts. No person is to stand under suspended loads.

Use hoisting gear in good condition.



Keep long screws from getting warped. Support screw by appropriate means.

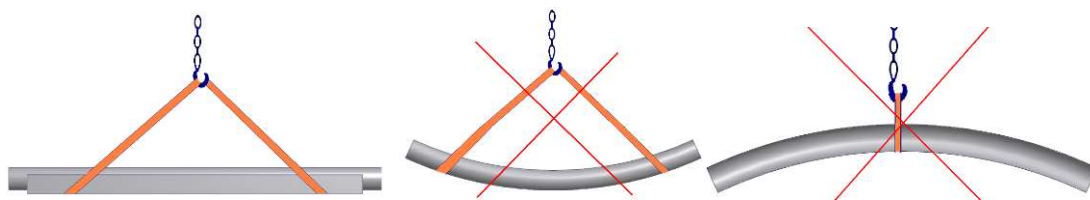

5.3 Storage

Storage period < 3 years	Check corrosion protection; renew or repair, if necessary. Check lubrication of moveable machinery, relubricate if necessary. Check oil level of gears; refill, if necessary.
Storage period > 3 years	Check corrosion protection; renew or repair, if necessary. Check lubrication of moveable machinery, relubricate if necessary. Clean spindle and grease with fresh lubricant along the whole length. Drain gear oil, and fill gear unit with the prescribed oil quantity and quality. Regrease for grease lubrication.

General information

6 Worm gear screw jacks, standard version

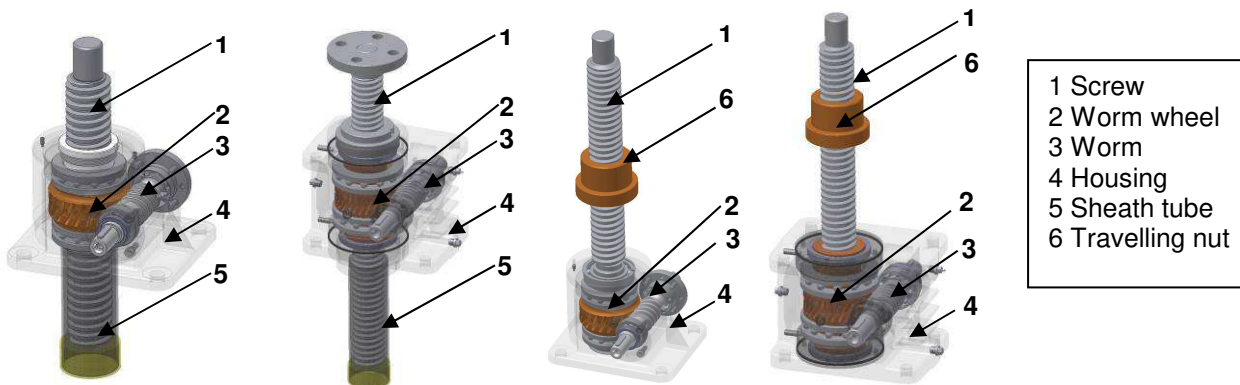

- | | |
|---|----------------|
| 1 | Screw |
| 2 | Worm wheel |
| 3 | Worm |
| 4 | Housing |
| 5 | Sheath tube |
| 6 | Travelling nut |

Feature	Description
Rotating worm wheel Ba1	Translation thread or ball screw nut integrated into the worm wheel
Lifting screw Ba1	Trapezoidal thread, buttress thread, multiple trapezoidal thread, ball screw
Rotating screw Ba2	From worm gear propelled trapezoidal, buttress, or ball thread spindle.
Lifting travelling nut Ba2	Travelling nut conducts the lift movement.
SHE:	Worm gear with grease lubrication
HSE:	Worm gear with oil lubrication
Thread spindle	with grease lubrication
Suitable for an ambient temperature -10 to +40 °C	If the temperatures deviate from these specifications, the design must be adapted by our technical office.

6.1 Safety worm gear screw jacks



The worm gear screw jacks are equipped with a long safety nut, and an electric nut breakage monitoring system for lifting tables acc. to EN 1570-1, elevating work platforms acc. to DIN EN 280, vehicle lifts acc. to DIN EN 1493 and stages and studios acc. to BGV C1/DIN56950-1.



The manufacturer is responsible for the risk assessment of the entire system.

Feature	Description
Safety nuts	To protect against falling of the load in case of wear of the carrying nut.
Visual wear indicator	For monitoring the wear of the carrying nut
Electrical nut breakage monitoring	For monitoring the carrying nut for breakage
Self-locking/self-braking spindle option	On lift devices that must safely brake in the event of the failure of a connection element, worm gear screw jacks with self-locking or self-braking screws are required
Speed monitoring option	To monitor the synchronisation of all screw jacks or the standstill of a screw jack in one lifting system with several worm gear screw jacks.
Standstill monitor option	
Load monitor option	Electronic load monitor for monitoring the power of the drives



The selection of self-locking or braking options must be made on a case by case basis, taking into account the complete system. Depending on lift speed and positioning accuracy, additional brake(s) will be required.

6.2 Safety nut (wear monitoring)

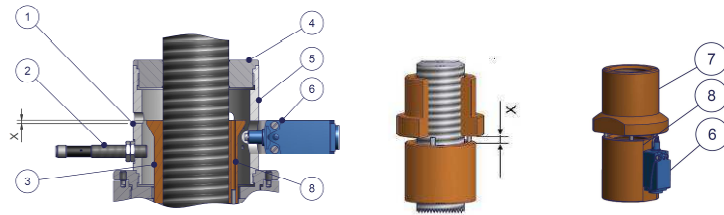

- 1 Visual wear monitoring
- 2 Inductive sensor
- 3 Pulse recession
- 4 Guide ring
- 5 Tube cap
- 6 Nut breakage limit switch
- 7 Travelling nut
- 8 Safety nut

Principle: With further wear, the gap X diminishes (documentation see 9.2.6)

Once the wear limit has been reached, the safety limit switch is activated.

The switch signals should be processed by the controller according to the requirements of the respective product standards.

Only possible with trapezoidal thread spindles or buttress thread screws.

6.3 Safety-trap nut (option for ball screw spindles)



If the ball screw nut malfunctions, the ball screw spindle catches on the thread of the trap nut. As a result, the power requirement of the drive motors increases. The unit needs to be switched off by the controller or otherwise by a load monitor.

6.4 Options for screw jacks Ba1 and Ba2

6.4.1 Protection against skimming "Se", "Ve";



The end stop is a safety device and should not be used as a "working stop". If the end stop is run against the block, this can cause damages to the screw or gears.

6.4.2 Ball thread spindle "Ku"



Please note during assembly and transport. Ball thread spindles are not self-locking. Driving only permitted with a brake motor.

6.4.3 Multi-gear trapezoidal thread screws



Please note during assembly and transport. Multi-gear trapezoidal screw are not self-locking. Driving only permitted with a brake motor.

6.4.4 Buttress thread screws "S"



Only in combination with 2 guide rings.

7 Assembly

Inspecting the used screw jacks for compliance with the technical requirements.

Add-on construction, supporting structure and groundwork is designed for the maximum forces.

For screw torques, see 7.11

Protect screws from soiling during transport, assembly, construction and storage.

Screws need to be protected during operation against soiling, e.g. by bellows, coils or on-site covers.



On worm gear screw jacks with oil lubrication, check the oil level, refill if necessary, insert bleed plug, pull pin at bleed plug.

If necessary, mount and set limit switch.

Avoid misalignment and angular offset.

Provide movable load support points if necessary.

Distortions increase power consumption and reduce the service life!

Carry out assembly and run-in phase without explosive atmosphere.



The ATEX marking on the incorporated components must correspond to the existing ATEX atmosphere.

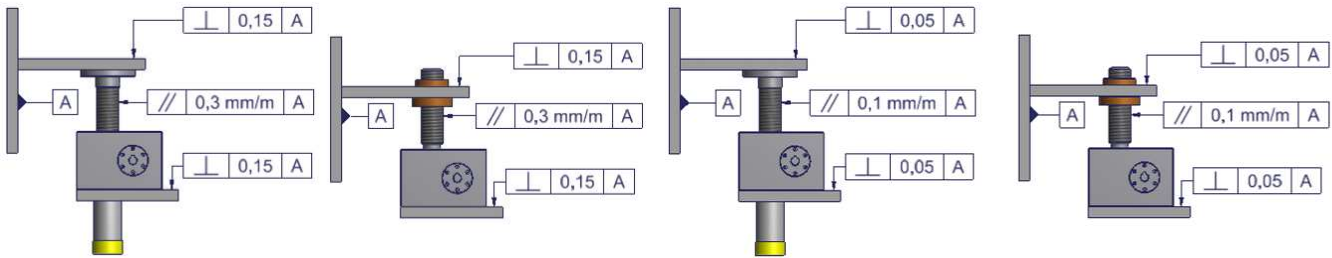

**SHE Tr screw
HSE Tr screw**

**SHE Ku screw
HSE Ku screw**

1. Align screw and screw jacks (e.g. with a spirit level, 0.3 mm/m), then screw tight, and anchor if necessary.
2. Make sure the screw is parallel to the on-site guides.
3. Avoid distortions. The worm shaft should turn easily and evenly throughout the entire lift height.
4. Clean screw and grease along the entire lift height.
5. **For HSE and SHE with oil lubrication:**
Pull tapered pin at the venting or insert pressure venting screw at the highest point.
Check lubrication level and top up if necessary.
6. **For SHE with grease lubrication:** Lubricate the gear using the grease gun at the lubrication nipple. Housing needs to be filled completely with grease.



For HSE for the ATEX area, insert the pressure bleed plug at the highest point for venting.

For multi-screw units

7. Check turning directions of all screw jacks.
8. Even out uneven support surfaces (use metal shims).
9. Move the screws/travelling nuts to the same height before depositing, aligning and fastening the load.



To even out alignment errors between the individual elements, use rotationally elastic couplings, rotationally elastic propeller shafts or cardan shafts.



Monitor the lubrication film and the screw temperature during the run-in phase. If there is rapid lubrication consumption and excessive temperature despite compliance with the duty cycles and the maximum capacity specifications, this indicates impermissible lateral forces.

7.1 Fitting positions SHE

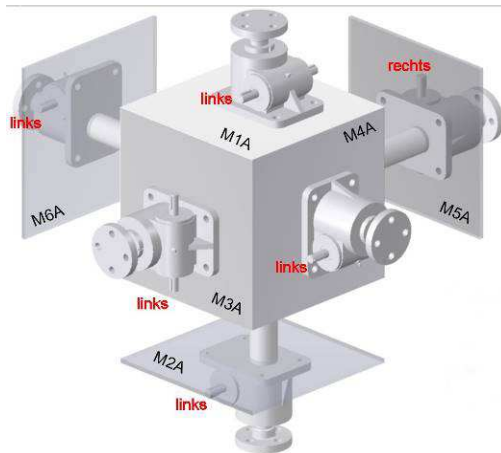

Version A

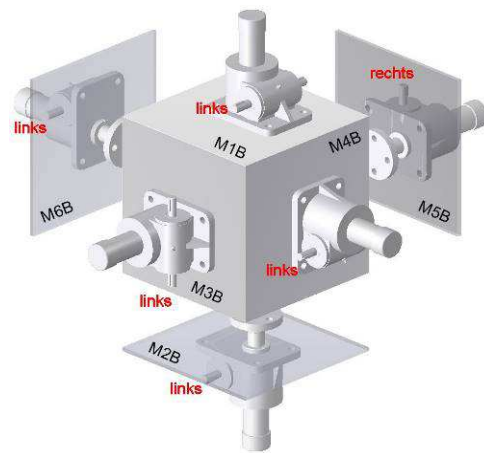

Version B

7.1.1 SHE oil fixtures with oil lubrication

	Fitting position	M1A M1B	M2A M2B	M3A M3B	M4A M4B	M5A M5B	M6A M6B
	Pos 2						
	Pos 3						
	Pos 4						
	Pos 5						
	Pos 6						

7.2 Fitting positions HSE

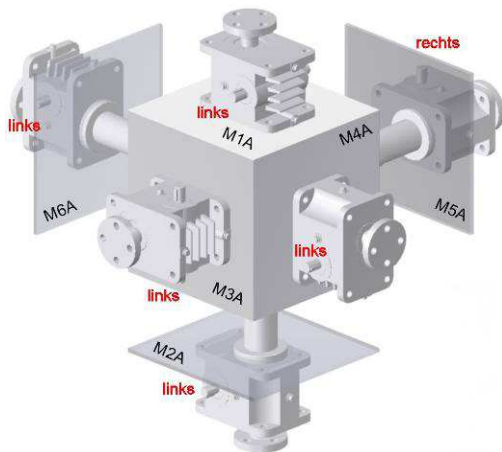

Version A

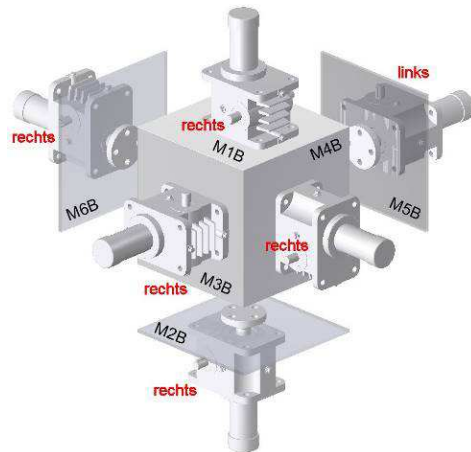

Version B

7.2.1 HSE oil fixtures

	Mounting position	M1A M1B	M2A M2B	M3A M3B	M4A M4B	M6A M6B
	Pos 1					
	Pos 2					
	Pos 3					
	Pos 4					
Pos 5						



Oil sight glass or lock screw



Fill screw/venting



Drain screw

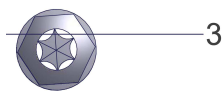
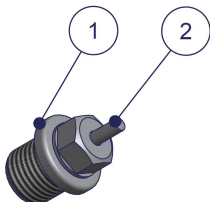

Pressure bleed plug
(e.g. ATEX)

- 1 Bleed plug
- 2 Venting pin
(pull at initial operation)
- 3 Oil level



Tighten the venting screws always to the highest position.

7.3 Pivot version

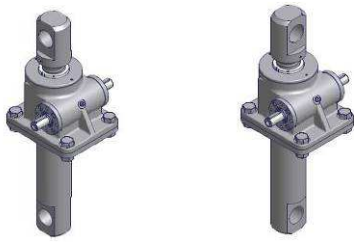

Version P Version Q

Version P or Q defines the position of the worm shaft towards the swivel axis.

Display SHE (also deliverable as HSE)

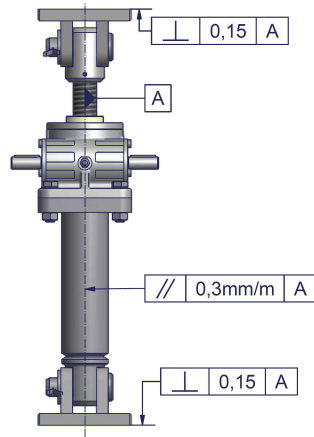

No side forces due to alignment errors. Distortions increase power consumption and reduce the service life!
If necessary, install movable load support points or pivoting bearings.
Fasten screw jacks using only quality bolts and screws.
Secure bolts and screws.

7.4 Assembly of the inductive limit switches

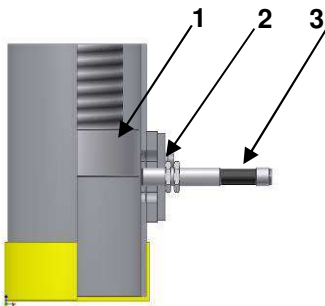

- 1 Switching cam
- 2 Counter nut
- 3 Inductive sensor
- 4 Sensor fittings

Run switch cam on sight
Screw in the displacement sensor until it is aligned with the inner diameter of the tube wall thickness.
Secure the sensor emitter by tightening the hexagon nut and ensure that the emitter does not turn or the position is otherwise changed.

	If the sensor protrudes toward the interior, it will be destroyed.	
	Observe the maximum tightening torque!	
Material	Type	Maximum tightening torque [Nm]
Metal	M 8	2,5
	M 12	7
	M 18	35



4

Adjusting the switch point:

Loosen screws (4).
Slide the holding plate up or down
Tighten screws. Observe the tightening torques!

7.5 Assembly of electromechanical limit switches

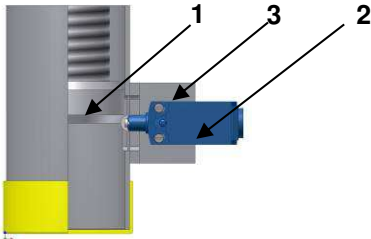

- 1 Switching cam
- 2 Holding plate
- 3 Mechanical limit switch
- 4 Limit switch fittings

1. Run switch cam on sight.
2. Screw the limit switch (3) onto the bracket; tighten screws only slightly. Push the switch all the way in until the roll rests against the switch cam phase.
3. Measure limit switch distance (for example, the back edge of the switch housing).
4. Pull the limit switch back 1 mm and tighten it.
5. Carry out the lift test and set the actual lift.
Individual adjustments $\pm x$ according to the order confirmation / drawing



Secure screws against unintentional loosening.

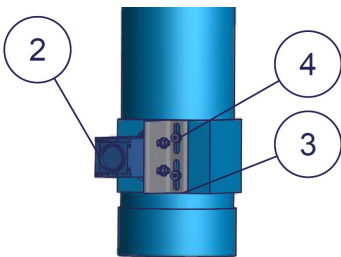

Adjusting the switch point:

Loosen screws (4).
Slide the holding plate (3) up or down to the desired position.
Retighten the screws. Observe the tightening torques!

7.6 Assembly of safety nut



Pay attention to the installation position and force directions (pull/push)

The safety nut has to be placed subsequently in the load direction of the travelling nut.

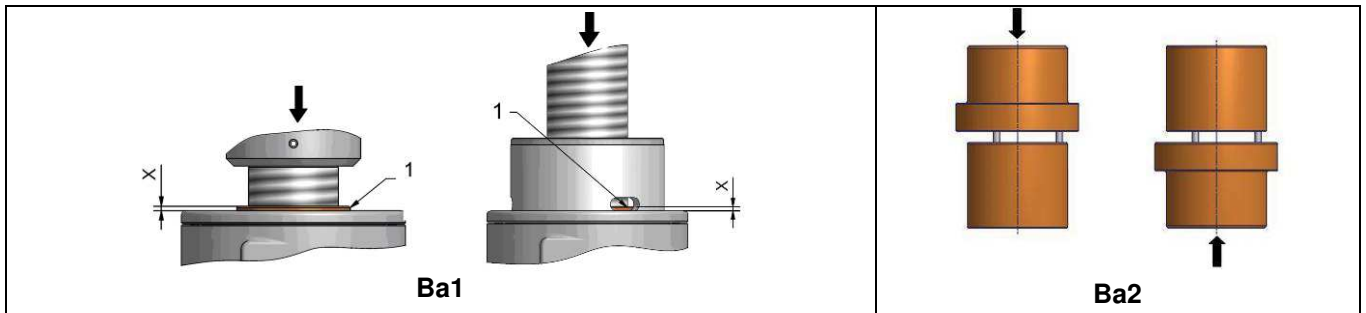

- 1 Wear indication ring
- = Load direction

7.7 Installing the nut breakage limit switch (Ba1)

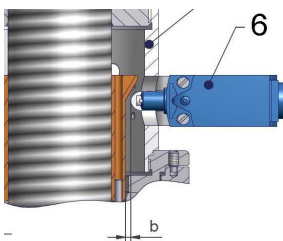

1. Screw the limit switch (6) onto the bracket; tighten screws only slightly. Push the switch all the way in until the roll rests against the safety nut.
2. Measure limit switch distance (for example, the back edge of the switch housing).
3. Pull the limit switch back by the distance $b (=1 \text{ mm})$ and tighten it.



Secure screws against unintentional loosening.
Observe the tightening torques!

7.8 Installing the nut breakage limit switch (Ba2)

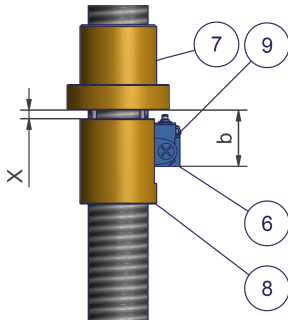

1. Screw limit switch (6) onto safety nut (8), slightly tighten screw (9).
2. Adjust distance of the limit switch (measurement b).
3. Tighten screws



Secure screws against unintentional loosening.
Observe the tightening torques!

7.8.1 Distance b, SHE series

Size	Dimension b	Distance X	Limit switches	Drawing no.
SHE 1.1	62,5	5	XCK T2110P16	13.02.103/0023
SHE 3.1	66	10	XCK T2110P16	13.02.105/0000-2600
SHE 5.1	68	10	XCK T2110P16	13.02.108/0000-2600
SHE 15.1	66	10	XCK T2110P16	13.02.109/0000-2600
SHE 20.1	66	10	XCK T2110P16	13.02.115/0028
	86	10	XCK T2110P16	13.02.115/0027
SHE 25	87	10	XCK P102	13.02.012/0046-0000
SHE 35.1	94	15	XCK T2110P16	13.02.035/0016-0000
	80	10	XCK T2110P16	13.02.035/
SHE 50.1	99	15	XCK T2110P16	13.02.113/0006
SHE 75	97	15	XCK T2110P16	13.02.075/0000-2300
SHE 100.1		15		

7.8.2 Dimension b, HSE series

Size	Dimension b	Distance X	Limit switches	Drawing no.
HSE 32				
HSE 36.1	66	10	XCK T2110P16	16.02.101/0000-0000BI05
HSE 50.1	66	10	XCK T2110P16	16.02.113/0000-0000BI05
HSE 63.1	66	10	XCK T2110P16	16.02.114/0000-0000BI05
HSE 80.1	66	10	XCK T2110P16	16.02.104/0000-0000BI05
HSE 100.1	130	15	XCK J 567	16.02.105/0000-0000BI05
	89,5	10	XCK P 2102P16	16.02.105/0013
HSE 125.1	88	15	XCK P 2102P16	16.02.106/0001-0000

7.9 Installing the pulse generator (rotational speed monitor)

7.9.1 Pulse by cam

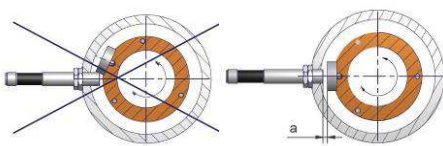

1. Turn the worm wheel (worm) until the pulse cam is visible in the fixing thread of the pulse generator.
2. Screw in the sensor until it contacts the outer diameter of the pulse cam.
3. Turn the transmitter back again by 0.5 to 1 rotation until the distance between the transmitter and the pin is between 0.5 and 1 mm (measurement a).
4. Tighten the hexagon nut to fasten the pulse generator. When doing this, ensure that the pulse generator does not turn!

7.9.2 Pulse by recession or flattening

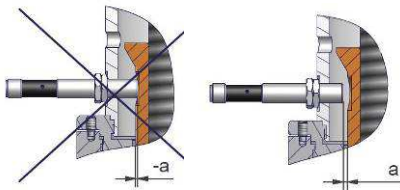

1. Turn the worm wheel (worm) until the pulse levelling is not visible in the fixing thread of the pulse generator.
2. Screw in the pulse transmitter until it lies at the **outer diameter** of the safety nut.
3. Turn the transmitter back again by 0.5 to 1 rotation until the distance between the transmitter and the safety nut is between 0.5 and 1 mm (dimension a).
4. Tighten the hexagon nut to fasten the pulse generator. When doing this, ensure that the pulse generator does not turn!



**Should the sensor extend inwards, it will break and its sheared off parts have to be removed from the gears.
Observe the maximum tightening torque!**

7.10 Mechanical fastening

7.10.1 Screw jack housing

SHE	Size	0,5	1.1	3.1	5.1	15.1	20.1	25	35	50.1	75	100.1	150.1
Screws (quality class min. 8.8)		M 8	M 8	M 12	M 16	M 18	M 24	M 33	M 33	M 42	M 42	M 48	M 48
Screws head II		M 6	M 8	M 12	M 16	M 18	M 24	M 24	M 30	M 30	M 42	M 48	M 48
Number of screws		2	4	4	4	4	4	4	4	4	6	6	8

HSE	Size	32	36.1	50.1	63.1	80.1	100.1	125.1	140.1	200.1
Screws (quality class min. 8.8)		M 8	M 8	M 12	M 16	M 20	M 24	M 36	M 42	M 64
Number of screws		4	4	4	4	4	4	8	4	4

7.10.2 Screw heads

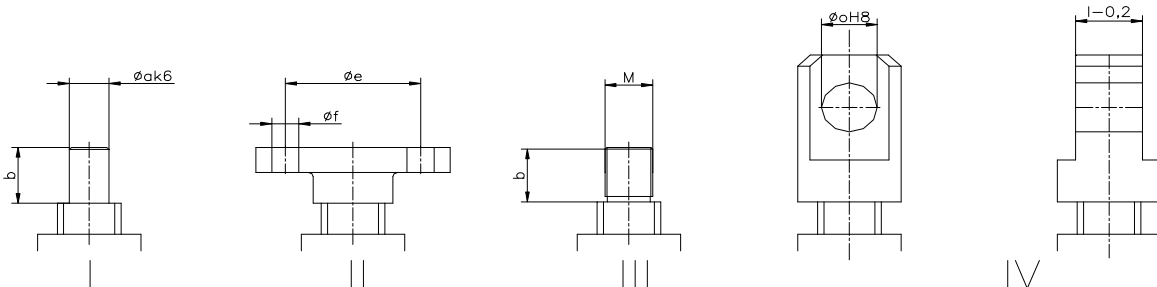

SHE	Size	0,5	1.1	3.1	5.1	15.1	20.1	25	35	50.1	75	100.1	150.1
$\varnothing a_{k6}$		18h9	15	20	25	40	50	70	80	100	110	140	160
b		20	24	30	40	50	54	63	80	125	125	175	200
$\varnothing e$		45	50	75	85	105	140	155	200	225	270	280	310
n x $\varnothing f$		4 x 7	4 x 9	4 x 14	4 x 17	4 x 21	4 x 26	4 x 27	4 x 33	4 x 35	6x45	6 x 52	8x52
Thread M		18x1.5	16x1.5	22x1.5	30x2	40x3	56x3	70x3	80x3	100x5	120x6	140x6	160x6
$\varnothing o_{H8}$		15	20	25	35	50	60	70	80	100	120	140	160
l-0.2		20	25	30	42	60	75	90	105	120	140	160	180

HSE	Size	32	36.1	50.1	63.1	80.1	100.1	125.1	140.1	200.1
$\varnothing a_{k6}$		18h9	15	20	30	40	50	80	95	130
b		17	24	29	39	49	54	79	99	119
$\varnothing e$		45	50	65	85	105	135	170	205	270
n x $\varnothing f$		4 x 7	4 x 9	4 x 14	4 x 17	4 x 21	6 x 26	8 x 30	8 x 33	8 x 45
Thread M		18x1.5	16x1.5	20x1.5	30x2	42x3	56x3	80x3	100x4	140x4
$\varnothing o_{H8}$		15	20	25	35	50	60	80	100	140
l-0.2		20	25	30	40	60	75	100	120	160



For the exact mounting dimensions, please request our dimensional drawings.

7.10.3 Joint heads



Screw jacks with joint heads are available as special models.

When using joint bearings or joint heads, a torsional lock needs to be installed on the gear side.

7.11 Screw tightening torques

Coarse-pitch thread	Tightening torque M _A [Nm]		
	Quality 8.8	Quality 10.9	Quality 12.9
M 4	2,8	4,1	4,8
M 6	9,5	14	16,5
M 8	23	34	40
M 10	46	68	79
M 12	79	117	135
M 16	195	280	330
M 20	390	560	650
M 24	670	960	1120
M 27	1000	1400	1650
M 30	1350	1900	2250
M 36	2330		
M 42	3676		
M 45	5502		
M 48	5636		
M 56	8856		

8 Initial operation

Always observe and follow these operating instructions when using the equipment.

Any use other than the intended use is prohibited.

Commissioning may only be performed by authorised personnel.

Check lubrication level.

Check limit switches.

Pay attention to the proper polarization of the electrical installation the the motor's sense of direction.



Put lift unit into operation without a load. (1x lifting 1x lower)

Operate intermittently, gradually increasing the load.

During initial operation, constantly control the operating temperature, the motor's current consumption and the spindle contact pattern.

After 5 hours of operation, check that the screws are tight. Retighten where necessary.

Monitor the lubrication film and the screw temperature during the run-in phase. Rapid lubrication consumption and excessive temperature indicate undue lateral forces even if the power-on time and the maximum power specifications are complied with.

Carry out commission and run-in phase in secure explosive-free atmosphere.

Check the earthing of the mounted parts. (Discharge resistance less than 10⁶Ω)



Units for spaces with explosion hazards should be checked by a specially authorised person before commissioning. (TRBS 1203-1). Observe the ATEX safety instructions in Chapter 3.2.

Check that the ATEX marking corresponds to the existing atmosphere.

9 Maintenance and inspection



Regular (at least 1x per year) inspection/maintenance must be performed by a qualified person (in acc. with TRBS 1203-1)⁷ contracted by the operator.

All tests and modifications must be documented (e.g. machine file, inspection log).

The operator has to count or measure the alternations of load or operating hours and document them.

Risk analysis by the manufacturer of the overall system.



Carry out maintenance/inspection in secure explosive-free atmosphere.

Conduct a technical ATEX safety inspection by an especially qualified person (acc. to TRBS 1203-1) every 3 years.



Power must be turned off before maintenance and inspection of the unit.



Observe to the pertinent safety regulations during maintenance and inspection.

Support the load.

9.1 Maintenance plans

Screw jack		Every 50 hours of operation**	Prior to every operation	Quarterly	Every 300 hours of operation or annually	Every 5 years or after 1,000 hours of operation
	SHE Ba1	Check the screw's grease level and refill if necessary.	Check screw jack externally for leaks.	Check the gear lubrication level and refill if necessary.	Safety test Grease the screw Check the gear lubrication level and refill if necessary. Damaged surface treatment should be properly repaired immediately Grease the torsional lock	Change the grease in the gear box
	SHE Ba2					
	HSE Ba1					
	HSE Ba2					Gear box oil change

** For special operating conditions, the lubrication intervals can be coordinated with us.

9.2 Maintenance instructions

9.2.1 Wear limits

Tr screw	14x4	18x4	18x6	20x4	24x5	26x6.28	30x6	35x8	40x7
Max. wear [mm]	1,0	1,0	1,5	1,0	1,3	1,5	1,5	2	1,6
Tr screw	40x8	50x9	58x12	60x9	60x12	65x12	70x10	70x12	80x10
Max. wear [mm]	2	2,3	3,0	2,3	3,0	3,0	2,5	3,0	2,5
Tr screw	90x16	100x10	100x16	120x14	120x16	140x20	160x20	190x24	220x28
Max. wear [mm]	4,0	2,5	4,0	3,5	4,0	5,0	5,0	6,0	7,0

Wear limits of special pitches upon request or otherwise in operating instructions specific for the order.

⁷ We recommend having this check performed by the service department of CMCO.

9.2.2 Standard screw jack with trapezoidal thread screw

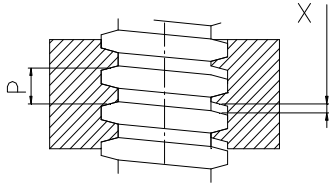

Safety test:

The wear of the nut thread in the worm wheel / in the travelling nut needs to be checked regularly, at least once per year.
Replacement is urgently required once the wear limit has been reached.
X = maximum wear (see Table 9.2.1)

9.2.3 Standard screw jack with ball thread screw



Safety test:

Pay attention to the running noises of the Ku screws during operation. An increase in noise indicates wear of the Ku nuts. The nuts and screws need to be replaced promptly.
The Ku screws/nuts should generally be exchanged at the end of its service life.

9.2.4 Safety screw jacks



For utilisation in systems in acc. with EN 280, EN1570-1, EN1593; DIN 56950-1

In accordance with BetrSichV, lifting equipment must undergo an examination by an authorised person in intervals (at least 1x per year) specified by the operator (TRBS 1203-1).⁸

9.2.5 Screw jacks with safety nut

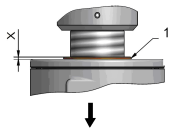

1 = Wear indication ring

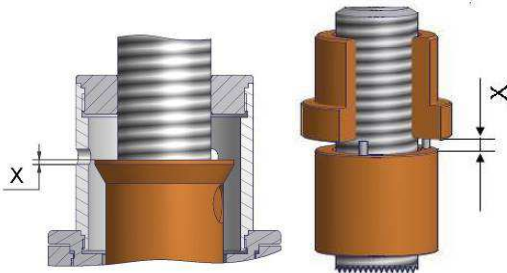
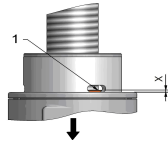

Safety test:

Check the wear in the screw jacks (dimension x) of the translation thread in the worm wheel / travelling nut.
Prompt replacement of the carry nut and safety nuts is required should the safety nut (wear indication ring) align with the upper and lower edge of the housing or the wear limit has been reached (dimension X).

Wear limit = X - max. wear
(see Table 9.2.1)

9.2.6 Wear measurement log

We recommend recording the new condition and the results from measuring the wear (dimension X).

	Screw jack 1	Screw jack 2	Screw jack. 3	Screw jack 4	Date/Signature
New condition Dimension X					
Wear measurement on _____					
Wear measurement on _____					
Wear measurement on _____					
Wear measurement on _____					

9.2.7 Spindle lubrication



Clean the screw with grease evenly with a brush.

We recommend an automatic lubricant dispenser in places of difficult accessibility, a longer power time or in dirty environments.

Automatic lubricant dispensers are also available with ATEX conformity.

⁸ We recommend having this check performed by the service department of CMCO.

9.2.8 Gear unit lubrication

For information on the oil level, location of the oil sight glasses, venting and drain screw, refer to Chapter 7.1.1 and 7.2.1 Mounting positions

9.2.9 SHE with grease lubrication

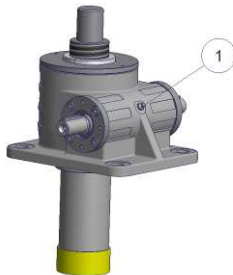

Lubricate the lubrication nipple (1) at the gear box with the grease gun. Press the grease until it discharges from the seal lip or from the venting bore.
Max. grease amount 20 ml or at least SHE 20.1 5% of the complete filling amount (see 9.2.12)
Observe screw jack and attachment parts.
Remove excess grease (e.g. in sheath tube or bellows).

9.2.10 Grease the torsional lock (V)



Lubricate the lubrication nipple (2) at the guiding tube with the grease gun. Grease amount about 20 ml at 500 mm lift height.

9.2.11 HSE and SHE with oil lubrication

Check oil fill level at the oil sight glass and refill if necessary.
Visual check for leaks

9.2.12 Lubrication amounts

SHE gear box with grease lubrication

SHE unit size	0,5	1.1	3.1	5.1	15.1	20.1
Grease amount about (kg)	0,05	0,1	0,2	0,35	0,9	2,0

SHE unit size	25	35	50.1	75	100.1	150.1	200.1
Grease amount about (kg)	1,3	2,5	4	5	10	10	

Gear box with oil lubrication

SHE unit size	0,5	1.1	3.1	5.1	15.1	20.1
Oil amount about (l)	0,05	0,1	0,2	0,35	0,9	2,0

SHE unit size	25	35	50.1	75	100.1	150.1	200.1
Oil amount about (l)	1,3	2,5	4	5	10	10	

HSE size	32	36.1	50.1	63.1	80.1	100	125	140	200
Oil amount about (l)	0,07	0,15	0,4	0,7	1,5	2,1	5,0	10	15,5

9.3 SHE with low-viscosity grease level in the lift gear box

Low-viscosity lubrication according to order confirmation, The maintenance of the lift gear box with low-viscosity grease level does not differ from screw jacks with standard grease filling.



Observe the types of grease according to the order confirmation

10 Decommissioning



When decommissioning the system, recycle or dispose of the various system components and/or screw jacks according to the legal requirements.

11 Lubricants

	Ambient temperature range [°C]	Lubricant ¹⁾	ISO-NLGI ¹⁾					
SHE/Merkur gear box and Tr. screws SHE0.5-100 M1 -M8	-30 up to 0	Grease KP2E-40	NLGI 2	SKF LGLT 2 4)	ISOFLEX LDS 18 Special A	Molub-Alloy 243 Arktik	UNIREX S 2	gleitmo 585K
	-15 to +40	Grease KP2K-20	NLGI 2	EP 2 special grease for lifting gears	Klüberplex BE 11-462		Beacon EP 2	gleitmo 585K
	+20 to +80	Grease KP2K-20	NLGI 2	EP 2 special grease for lifting gears	Klüberplex BE 11-462		Beacon EP 2	gleitmo 585K
	+40 to +180	Grease KP2S-20	NLGI 2		Klübersynth BH 72-422			URETHYN E/M 2
SHE screws BG150 / BG200	0 to +50 °C	Grease KP0K-20	NLGI 0		Grafloscon C-SG 2000 Ultra	Molub-Alloy 936 SF Heavy		CEPLATTYN KG 10 HMF 2500
SHE gears BG150 / BG200	0 to +50 °C	CLP	VG 680		Klüberoil GEM 1-680 N	Optigear BM 680		GEARMASTER CLP 680
SHE screws (trapezoidal thread)	-30 up to 0	Grease KP2E-30		SKF LGLT 2 4)	ISOFLEX LDS 18 Special A	Molub-Alloy 243 Arktik	UNIREX S 2	gleitmo 585K
	-15 to +80	Grease KP2K-20		PS-Grease 011	Klüberplex GE 11-680	Molub-Alloy 936 SF Heavy		gleitmo WSP 5040
	+40 to +120	Grease KP2S-20			Klübersynth BH 72-422			URETHYN E/M 2
HSE gear	-30 up to 0	Synth. oil CLP-PG	VG 68		Klübersynth GH 6-80			
	-15 to +40		VG220		Klübersynth GH 6-220	Tribol 800/220	Glycolube 220	Gearmaster PGP 220
	+40 to +120		VG680		Klübersynth GH 6-680			Gearmaster PGP 680
SHE gear oil lubrication	-30 up to 0	Synth. oil PGLP	VG100		Klübersynth GH 6-100			
	-15 to +40	Mineral oil CLP	VG220	Divinol ICL ISO 220 5)	Klüber oil GEM 1-220 N	Optigear BM 220	Spartan EP 220	Gearmaster CLP 220
	+20 to +80	Mineral oil CLP	VG680		Klüberoil GEM 1-680 N	Optigear BM 680	Spartan EP 680	Gearmaster CLP 680
	+40 to +120	Synth. oil PGLP	VG680		Klübersynth GH 6-680			Gearmaster PGP 680
Ku screws	-30 up to 0	Grease KP2E-30	NLGI 2	SKF LGLT 2 4)	ISOFLEX LDS 18 SPEZIAL A			gleitmo 585 K
	-15 to +80	Grease KP1K-20	NLGI 1 ¹⁾		Stabutherm GH 461			URETHYN E/M 2
	+40 to +120	Grease KP1K-20	NLGI 1 ¹⁾		Stabutherm GH 461			URETHYN E/M 2

Printed bold = Standard lubricants: Factory-filled gear lubrication or otherwise lubrication recommendation for screws

Attention: The alternatives to our standard lubricants are specifications of the lubricant manufacturers.

Pfaff-silberblau does not have any references whether the lubricants meet the manufacturer specifications.

Lubricant selection: The temperature ranges refer to the ambient temperature. Higher lubricant temperatures that may result during the operation of the drive elements have already been taken into account.

Standard temperature range: -15 °C to +40 °C

Only if the limits of the standard temperature range is exceeded should lubricants of other temperature ranges be used.

To operate the drive elements in temperature ranges that deviate from the standard, design modifications are necessary along with possible construction measures. Observe the technical data according to the order confirmation and the operating instructions.

Observe the lubricant specifications in the type plate.

Mineral and synthetic lubricants should not be mixed together. It is recommended to generally not mix lubricants or to check the composition.

1) Specifications refer to the factory lubricant	4) SKF GmbH
2) Critical start-up characteristics at low temperatures should be observed.	5) Zeller+Gmelin GmbH & Co. KG



Used lubricants are to be disposed of in accordance with legal requirements!



12 Einbauerklärung / Declaration of incorporation / Déclaration d'incorporation

für unvollständige Maschinen im Sinne der EG- Maschinenrichtlinie 2006/42/EG, Anhang II, Nr. 1B	for incomplete machines according to EC machine directive 2006/42/EC, Annex II, No. 1B	pour machines incomplètes conformément à la directive européenne relative aux machines 2006/42/CE, annexe II, n 1B
Spindelhubelemente SHE; HSE Ba 1 und Ba 2 Antriebselement zum Einbau in eine Maschine	Worm Gear Screw Jack SHE and HSE type 1 and type 2 Actuator element for assembly in a machine	Vérins à vis sans fin SHE et HSE type 1 et type 2 Propulsif élément pour assemblée dans une machine
ist eine unvollständige Maschine nach Artikel 2g und ausschließlich zum Einbau in eine Maschine oder zum Zusammenbau mit anderen Maschinen oder Ausrüstung vorgesehen.	is an incomplete machine according to Article 2 g and has been designed exclusively for installation in a machine or for assembly with other machines or equipment.	est une machine incomplète selon l'article 2g et a été conçue uniquement pour être montée dans une machine ou à être assemblée avec d'autres machines ou équipement.
Folgende grundlegenden Sicherheits- und Gesundheitsschutzanforderungen gemäß Anhang I dieser Richtlinie kommen zur Anwendung und wurden eingehalten 1.1.2; 1.1.3; 1.1.5; 1.3.2; 1.3.3; 1.3.4; 1.3.7; 1.3.9; 1.5.2; 1.7.3; 1.7.4; 4.1.2.3; 4.1.2.6	The following basic health and safety requirements in Annex I to this Directive are applicable and have been observed 1.1.2; 1.1.3; 1.1.5; 1.3.2; 1.3.3; 1.3.4; 1.3.7; 1.3.9; 1.5.2; 1.7.3; 1.7.4; 4.1.2.3; 4.1.2.6	Les exigences suivantes de sécurité et relatives à la santé, conformes à l'annexe I de cette directive, ont été appliquées et respectées 1.1.2; 1.1.3; 1.1.5; 1.3.2; 1.3.3; 1.3.4; 1.3.7; 1.3.9; 1.5.2; 1.7.3; 1.7.4; 4.1.2.3; 4.1.2.6
Die speziellen technischen Unterlagen gemäß Anhang VII B wurden erstellt und sie werden der zuständigen nationalen Behörde auf Verlangen in elektronischer Form übermittelt	The special technical documentation referred to in Annex VII B has been prepared and will be forwarded to the competent national authority, upon request in electronic form	La documentation technique spéciale conforme à l'annexe VII B a été préparée et sera transmise aux autorités nationales compétentes, également sous forme électronique, si nécessaire.
Diese unvollständige Maschine ist in Übereinstimmung mit den Bestimmungen der folgenden EG Richtlinien	This incomplete machine is in compliance with the provisions of the following EC directives	Cette machine incomplète est conforme aux dispositions des directives européennes suivantes
Angewendete harmonisierte Normen, insbesondere:	Applied harmonised standards, in particular: DIN EN 1494:2000; DIN EN ISO 12100:2010	Normes harmonisées utilisées, en particulier :
Angewendete nationale Normen und technische Spezifikationen, insbesondere:	Applied national technical standards and specifications, in particular:	Normes et spécifications techniques nationales qui ont été utilisées, notamment
Diese unvollständige Maschine darf erst dann in Betrieb genommen werden, wenn festgestellt wurde, dass die Maschine, in die diese unvollständige Maschine eingebaut werden soll, den Bestimmungen der EG-Maschinenrichtlinie entspricht	This incomplete machine may only be put into operation if it has been determined that the machine into which this incomplete machine will be installed complies with the provisions of the EC machine directive	Cette machine incomplète ne doit être mise en service que lorsqu'il a été déterminé, que la machine dans laquelle cette machine incomplète doit être montée, est conforme aux dispositions de la directive européenne relative aux machines

Ort/Datum Kissing, 03.04.2019

COLUMBUS McKINNON Engineered Products GmbH
Am Silberpark 2-8, 86438 Kissing, Germany
www.pfaffsilberblau.com
Ulrich Hintermeier
Director operations

Der Unterzeichnende ist bevollmächtigt die technischen Unterlagen gemäß Anhang VII A zusammenzustellen und der zuständigen Behörde auf Verlangen zu übermitteln.	The undersigned is authorised to prepare the technical documentation referred to in Annex VII A and submit it to the responsible authorities on request.	Le signataire est habilité à réunir la documentation technique spéciale conforme à l'annexe VII A et à la transmettre aux autorités compétentes si nécessaire.
--	--	--



<p>Einbauerklärung für unvollständige Maschinen im Sinne der EG- Maschinenrichtlinie 2006/42/EG, Anhang II, Nr. 1B</p>	<p>Declaration of incorporation for incomplete machines according to EC machine directive 2006/42/EC, Annex II, No. 1B</p>	<p>Déclaration d'incorporation pour machines incomplètes conformément à la directive européenne relative aux machines 2006/42/CE, annexe II, n 1B</p>
<p>Spindelhubelemente SHE; HSE Ba 1 und Ba 2 mit Sicherheitseinrichtungen Antriebselement zum Einbau in Hubtische, Hebebühnen, Hubarbeitsbühnen oder Fahrzeughebebühnen</p>	<p>Worm Gear Screw Jack SHE and HSE type 1 and type 2 with safety devices Actuator element for assembly in lifting tables, lifting platforms, working platforms or vehicle lifting platforms</p>	<p>Vérins à vis sans fin SHE et HSE type 1 et type 2 avec équipement de sûreté Propulsif élément pour installation dans table de levage, plateforme élevatrice, plateforme de travail, plateforme de levage pour véhicule</p>
<p>ist eine unvollständige Maschine nach Artikel 2g und ausschließlich zum Einbau in eine Maschine oder zum Zusammenbau mit anderen Maschinen oder Ausrüstung vorgesehen.</p>	<p>is an incomplete machine according to Article 2 g and has been designed exclusively for installation in a machine or for assembly with other machines or equipment.</p>	<p>est une machine incomplète selon l'article 2g et a été conçue uniquement pour être montée dans une machine ou à être assemblée avec d'autres machines ou équipement.</p>
<p>Folgende grundlegenden Sicherheits- und Gesundheitsschutzanforderungen gemäß Anhang I dieser Richtlinie kommen zur Anwendung und wurden eingehalten 1.1.2; 1.1.3; 1.1.5; 1.3.2; 1.3.3; 1.3.4; 1.3.7; 1.3.9; 1.5.2; 1.7.3; 1.7.4; 4.1.2.3; 4.1.2.6</p>	<p>The following basic health and safety requirements in Annex I to this Directive are applicable and have been observed 1.1.2; 1.1.3; 1.1.5; 1.3.2; 1.3.3; 1.3.4; 1.3.7; 1.3.9; 1.5.2; 1.7.3; 1.7.4; 4.1.2.3; 4.1.2.6</p>	<p>Les exigences suivantes de sécurité et relatives à la santé, conformes à l'annexe I de cette directive, ont été appliquées et respectées 1.1.2; 1.1.3; 1.1.5; 1.3.2; 1.3.3; 1.3.4; 1.3.7; 1.3.9; 1.5.2; 1.7.3; 1.7.4; 4.1.2.3; 4.1.2.6</p>
<p>Die speziellen technischen Unterlagen gemäß Anhang VII B wurden erstellt und sie werden der zuständigen nationalen Behörde auf Verlangen in elektronischer Form übermittelt</p>	<p>The special technical documentation referred to in Annex VII B has been prepared and will be forwarded to the competent national authority, upon request in electronic form</p>	<p>La documentation technique spéciale conforme à l'annexe VII B a été préparée et sera transmise aux autorités nationales compétentes, également sous forme électronique, si nécessaire.</p>
<p>Diese unvollständige Maschine ist in Übereinstimmung mit den Bestimmungen der folgenden EG Richtlinien</p>	<p>This incomplete machine is in compliance with the provisions of the following EC directives</p>	<p>Cette machine incomplète est conforme aux dispositions des directives européennes suivantes</p>
<p>Angewendete harmonisierte Normen, insbesondere: DIN EN ISO 12100:2010; DIN EN 1494:2000; EN1570; EN280; EN1756; EN1493</p>	<p>Applied harmonised standards, in particular:</p>	<p>Normes harmonisées utilisées, en particulier :</p>
<p>Angewendete nationale Normen und technische Spezifikationen, insbesondere:</p>	<p>Applied national technical standards and specifications, in particular:</p>	<p>Normes et spécifications techniques nationales qui ont été utilisées, notamment</p>
<p>Diese unvollständige Maschine darf erst dann in Betrieb genommen werden, wenn festgestellt wurde, dass die Maschine, in die diese unvollständige Maschine eingebaut werden soll, den Bestimmungen der EG-Maschinenrichtlinie entspricht</p>	<p>This incomplete machine may only be put into operation if it has been determined that the machine into which this incomplete machine will be installed complies with the provisions of the EC machine directive</p>	<p>Cette machine incomplète ne doit être mise en service que lorsqu'il a été déterminé, que la machine dans laquelle cette machine incomplète doit être montée, est conforme aux dispositions de la directive européenne relative aux machines</p>

Ort/Datum Kissing, 03.04.2019





COLUMBUS McMINNON Engineered Products GmbH
Am Silberpark 24, 86436 Kissing, Germany
www.pfafsilberblau.com

Ulrich Hintermeier
Director operations

<p>Der Unterzeichnende ist bevollmächtigt die technischen Unterlagen gemäß Anhang VII A zusammenzustellen und der zuständigen Behörde auf Verlangen zu übermitteln.</p>	<p>The undersigned is authorised to prepare the technical documentation referred to in Annex VII A and submit it to the responsible authorities on request.</p>	<p>Le signataire est habilité à réunir la documentation technique spéciale conforme à l'annexe VII A et à la transmettre aux autorités compétentes si nécessaire.</p>
---	---	---



13 EG-Konformitätserklärung EC-Declaration of Conformity Déclaration "CE" de Conformité

<i>im Sinne der ATEX Richtlinie 2014/34/EU Anhang X B</i>	<i>as defined by ATEX Directive 2014/34/EU annex X B</i>	<i>conformément à la directive "CE" ATEX 2014/34/EU Annexe X B</i>
Hiermit erklären wir, dass	Herewith we declare that the supplied model of	Nous ne déclarons que le modèle
Spindelhubelemente SHE; HSE Ba 1 und Ba 2 ein Gerät im Sinne der RL 2014/34/EG Artikel 1 (3) ist und die Anforderungen gemäß Anhang II der RL 2014/34/EG erfüllt.	Worm Gear Screw Jack SHE and HSE type 1 and type 2 <i>an equipment as defined by EC Directive 2014/34/EC article 1(3) is and fulfills the requirement according to annex II of the Directive 2014/34/EC</i>	Vérins à vis sans fin SHE et HSE type 1 et type 2 <i>un appareil dans le sens de la directive 2014/34/EC article 1 (3) est et les exigences conformément à l'annexe II de la directive 2014/34/EC ré</i>
Das Spindelhubelement ist geeignet für den Einsatz in explosionsgefährdeten Bereichen entsprechend der Kennzeichnung	<i>The worm gear screw jack is suitable for the operation in hazardous environment according to the marking</i>	<i>vérins à vis sans fin est approprié pour l'application dans les secteurs explosifs conformément au marquage</i>
 II 2G ck-Ex h IIB T4 Gb U  II 2G D c-Ex h IIIB T135°C Db U		
Angewendete harmonisierte Normen, insbesondere:	Applied harmonised standards, in particular:	Normes harmonisées utilisées, notamment
<p>DIN EN 1127-1-2011 (Explosionsschutz Grundlagen und Methodik/ Explosion prevention Basic concepts and methodology/ Prévention de l'explosion Notations fondamentales et méthodologie)</p> <p>DIN EN ISO 80079-36 (Grundlagen und Anforderungen/ Basic method and requirement/ Prescriptions et méthode de bases)</p> <p>DIN EN ISO 80079-37 (Schutz durch konstruktive Sicherheit „c“, Zündquellenüberwachung „b“, Flüssigkeitskapselung „k“ Non-electrical type of protection constructional safety "c", control of ignition sources "b", liquid immersion "k" Mode de protection non électrique par sécurité de construction "c", par contrôle de la source d'inflammation "b", par immersion dans un liquide "k"</p> <p>2014/34/EU Anhang VIII / Annex VIII / annexe VIII</p>		
Angewendete nationale Normen und technische Spezifikationen, insbesondere:	Applied national technical standards and specifications, in particular:	Normes et spécifications techniques nationales qui ont été utilisées, notamment
Auftragsbestätigung bzw. technisches Datenblatt sind Bestandteil dieser Konformitätserklärung. Order confirmation or technical data sheet is part of these declaration of conformity		
Vor Inbetriebnahme ist die gesamte Anlage durch eine, für Explosionsgefährdung, besonders befähigte Person zu prüfen. Die technische Dokumentation für Spindelhubelemente der Kategorie 2 ist bei der benannten Stelle 0035 unter der Registriernummer 296/Ex-Ab 1498/10 hinterlegt.	Before commissioning, the complete system must be inspected by a person specifically qualified in explosion hazards. The technical documentation for worm gear screw jacks for category 2 is deposited at the notified body 0035 under registration number 296/Ex-Ab 1498/10.	

Ort/Datum Kissing, 03.04.2019



COLUMBUS McMINNON Engineered Products GmbH
Am Silberpark 29, 86436 Kissing, Germany
www.pfaff-silberblau.com

Ulrich Hintermeier
Director operations