



Translation
Operating Instruction/
Assembly Instruction
Quick lifting bevel gear
screw jack SHG
Type1 and Type2
www.pfaff-silberblau.com

Table of contents

1	General information and safety	3
1.1	Introduction	3
1.2	Explanation of the symbols	3
1.3	Glossary	3
1.4	Intended use	4
1.5	Accident prevention regulations - Guidebooks	4
1.6	General safety information	4
1.7	Type plate	5
1.8	Technical Data	6
2	Receipt of goods, storage, transport	6
2.1	Receipt of goods	6
2.2	Transport	6
2.3	Storage	7
3	Quick lifting bevel gear screw jack standard version	7
4	Safety screw jacks	8
4.1	Safety nut (wear indicator)	8
4.2	Safety-trap nut (optional with Ku screws)	8
4.3	Options for screw jacks Ba1 and Ba2	8
5	Assembly	9
5.1	Mounting positions	10
5.2	Assembly of the inductive limit switches	11
5.3	Assembly of electromechanical limit switches	11
5.4	Assembly of safety nut	12
5.5	Installing the nut breakage limit switch	12
5.6	Installing the pulse generator (rotational speed monitor)	12
5.7	Mechanical fastening	13
6	Initial operation	14
7	Maintenance and inspection	14
7.1	Maintenance plans	15
7.2	Maintenance instructions	15
7.3	Lubrication	16
8	Decommissioning	17
9	Einbauerklärungen Declaration of incorporation Déclaration d'incorporation	18

1 General information and safety









1.1 Introduction

These operating instructions describe the Pfaff-silberblau quick lifting bevel gear screw jacks of the SHG model series. Please refer to our order confirmation or worm gear screw jack compendium for details on the layout, design and permissible operating conditions for the drives. Always observe and follow these operating instructions when using the equipment.



- Read these operating instructions carefully before assembly or initial operation and have them available to all responsible persons.
- Observe the safety information.
- Store the operating instructions and documents carefully.

1.2 Explanation of the symbols

	Practical information
	Warning against a general hazard. Risk of injury due to neglect.
	Warning against electrical voltage. Severe risk of injury due to neglect.
	Information on the safety screw jacks
	Danger of explosion
	Important information for use in spaces with explosion hazards
	Important information
	Assembly and setting information
	Disposal

1.3 Glossary

SHG	Quick lifting bevel gear screw jack
Type 1 (Ba1)	Method of operation for type with lifting screw
Type 2 (Ba2)	Method of operation for type with rotating screw
Specifications	A = screw on housing cover side; B= screw on mounting surface side
Tr	Trapezoidal thread spindle
Ku	Ball screw spindle
S	Buttress thread screw
P	Screw pitch
DIN	German industry standards
EN	European norm
ISO	International standards
ID	Intermittent duty in % / h

1.4 Intended use

Quick lifting bevel gear screw jacks are partly completed machines and intended for installation in complete machines or to be used for assembly with a totality of machinery to create systems. They are drive elements that are employed for converting rotational movement into longitudinal movement and speed reduction or torque conversion.

The drive system may only be used for its designated purpose.

They may be used only under the application conditions specified in the operating instructions, in the technical documentation or in the order confirmation.



Operation outside the respective performance limitations / ambient conditions is not permitted.

Not suitable for use in spaces with explosion hazards.

Not suitable for use in aggressive environments. If not constructed especially for these applications.

Modifications to the screw jacks as well as the attachment of additional devices are only permitted with our express and written authorisation.

Pay attention to the technical data and functional description!

	If stated in the order confirmation, the worm gear screw jacks with corresponding additional supplementary equipment comply with the requirements of various standards and guidelines:
--	--

1.5 Accident prevention regulations - Guidebooks

Observe the relevant instructions, regulations, and standards in the country of use. In Germany, these are currently:

		Rules and regulations
EC machinery directive		2006/42/EC
Machine safety		DIN EN ISO 12100-1 DIN EN ISO 12100-2
Lift devices		DIN EN 1494
	Lifting tables Lift work platforms Loading platforms Car hoists Stages and studios Stage mechanics, safety equipment	EN 1570 EN 280 EN 1756 EN 1493 BGV C1 DIN 56950

1.6 General safety information



Assembly, service, commissioning and maintenance only by authorised personnel familiar with the relevant regulations.



It is **forbidden** to transport people **or to loiter in the danger area** for devices not suitable for that. Exception: Screw jacks with safety features with appropriate intended use according to Chapter 1.4. in the framework of the corresponding product norm.



Not suitable for use in **spaces with explosion hazards!**



- Never grasp, cover, or block moving parts.
- Do not remove or disable the safety devices.
- The operational and safety limit switches have to ensure that the lifting process stops safely at the end positions.
- To prevent contact with rotating/moving parts, fasten protective covers (such as bellows, shaft caps) or make those areas of the machine inaccessible.
- Screw/Travelling nut must be fastened on-site or be turn-secured or equipped with the optional torsional lock (max. screw torque according to technical documents). The construction must be able to bear the screw torque securely.
- Ball thread spindles and multi-gear trapezoidal thread spindles are not self-locking. An appropriate brake device needs to be integrated into the system.
- In the standard version, the screw does not have any protection against unintended skimming out of the gear box (Ba1) or against the travelling nut driving out the screw. A protection against skimming needs to be realised either on site or by worm gear screw jacks with mechanical end stops.
- No lateral forces on the screw.
- Risk assessment by the manufacturer of the overall system.

1.7 Type plate

Type	G 25 N-Tr-F/Sf-B-W2L-Ru	Yr of manufacture	201x	
		Pressure/tension	-	kN
Art.Nr.	040040400	ED	-	%/h
Ser.No.	20242020-0001	Stroke / NL	150	mm
Grease / Oil	KP 2 K - 20	Lift speed	-	m/min

1.7.1 Type key

Range	G
Size	15/25/50/90
Ratio	1 / 2
Screw	Tr/ Ku
Design screw side	
Ba1	F
Ba2	K / H
Design tube side	
Ba1	F / S / Sf / V
Ba2	K
Design	A / B
Shaft configuration	W 1b / W1c / W1d/ W2lb / W2ld / W2Lb / W2Lc/ W3c / W4
Wheel configuration	Ru / Ro*

* For multi-screw units check turning directions of all screws/travelling nuts.

1.8 Technical Data

Model series SHE unit size		G 15	G 25	G 50	G 90
Max. lifting force	[kN]	15	25	50	90
Max. tension	[kN]	15	25	50	90
Screw Tr ¹		24x5	35x8	40x7	60x9
Ratio N		2:1	2:1	2:1	2:1
Lift per rotation at ratio N	[mm/U]	2,5	4	3,5	4,5
Ratio L		3:1	3:1	3:1	3:1
Lift per rotation at ratio L	[mm/U]	1,66	2,67	2,33	3
Max. drive power ² at 20°C ambient temperature and 20% ID/hr	[kW]	1,0	1,5	2,4	8,9
Max. drive power ² at 20°C ambient temperature and 10% ID/hr	[kW]	1,3	2,6	3,8	13
Screw efficiency	[%]	41	43	37	33
Torque-capacity-rotation speed at 20% ID/hr. and 20°C		See power table compendium on worm gear screw jacks			
Screw torque at max. lifting force t	[Nm]	29,4	73,2	123,4	398,5
Max. permit. torque on the drive shaft	[Nm]	50	125	175	1600
Max. permit. screw length at pressure load	[mm]	See offset diagram compendium worm gear screw jacks			

2 Receipt of goods, storage, transport

2.1 Receipt of goods



Startup with defective screw jacks is forbidden.



Immediately check if the contents of delivery correspond with the shipping documents upon receipt. No other warranties can be approved for subsequent defect claims.

Claims on defects and incompleteness are to be made immediately at Pfaff-silberblau.

Claims on perceivable damages due to transport are to be reported to the transport company immediately.



Small parts such as limit switches are usually delivered unattached and packed individually.

2.2 Transport



- Lift / transport the screw jack by the appropriate hoisting points.
- Pay attention to the attachment parts. No person is to stand under suspended loads.
- Use hoisting gear in good condition.



Keep long screws from getting warped. Support screw by appropriate means.

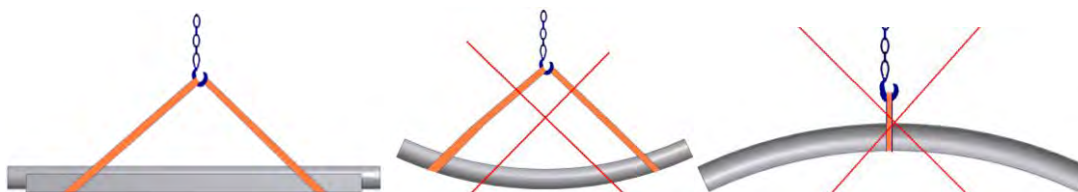

¹Also with Ku screw

² Max. permissible values with BA 1 and Tr screw. Higher values are possible using BA 2 or Ku screws

2.3 Storage

Storage period < 3 years	Check corrosion protection; renew or repair, if necessary. Check lubrication of moveable machinery, relubricate if necessary. Check oil level of gears; refill, if necessary.
Storage period > 3 years	Check corrosion protection; renew or repair, if necessary. Check lubrication of moveable machinery, relubricate if necessary. Clean spindle and grease with fresh lubricant along the whole length. Drain gear oil, and fill gear unit with the prescribed oil quantity and quality. Regrease for grease lubrication.

General information

3 Quick lifting bevel gear screw jack standard version

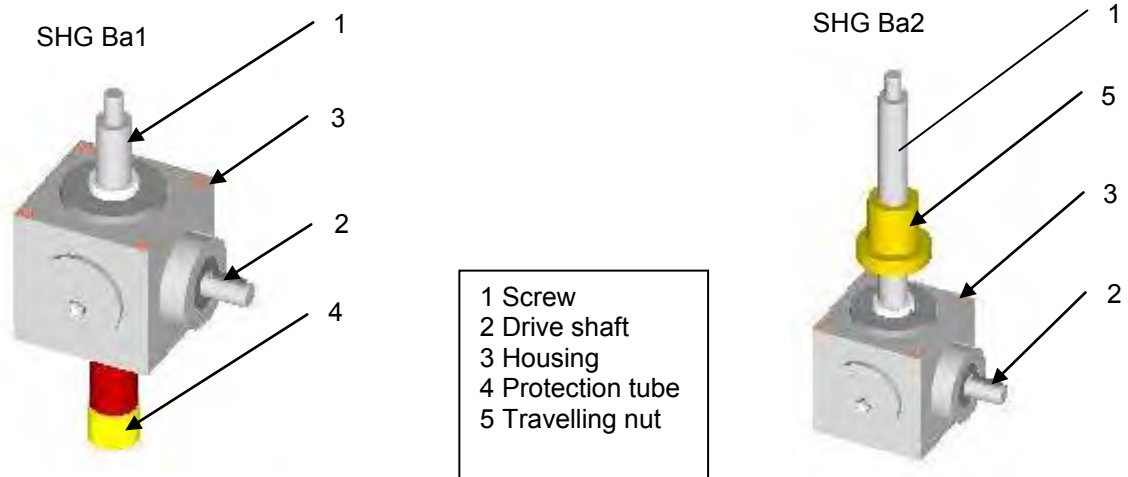

Feature	Description
Rotating bevel wheel Ba1	Translation thread or ball thread nut integrated into the bevel wheel.
Lifting screw Ba1	Trapezoidal thread, buttress thread, multiple trapezoidal thread, ball screw.
Rotating screw Ba2	From bevel gear rotated trapezoidal, buttress, or ball thread spindle
Lifting travelling nut Ba2	Travelling nut conducts the lift movement.
SHG:	Bevel gear with oil lubrication
Screw spindle with grease lubrication	
Suitable for an ambient temperature -10 to +40 °C	If temperatures deviate, a design by our technical office is necessary.

4 Safety screw jacks



The quick bevel gear screw jacks are equipped with a long safety nut, and an electric nut breakage monitoring system for lifting tables acc. to EN 1570, lift work platforms acc. to EN 280, car hoists acc. to EN 1493 and stages and studios acc. to BGV C1/DIN56950.



The manufacturer is responsible for the risk assessment of the entire system.

Feature	Description
Safety nuts	To protect against falling of the load in case of wear of the carrying nut.
Visual wear indicator	For monitoring the wear of the carrying nut
Electrical nut breakage monitoring	For monitoring the carrying nut for breakage
Speed monitoring option Standstill monitor option	To monitor the synchronisation of all screw jacks or the standstill of a screw jack in one lifting system with several worm gear screw jacks.
Load monitor option	Electronic load monitor for performance control of the drives
	Self-locking of braking needs to be inspected individually, taking the total system into account. Depending on lift speed and positioning precision, additional brake(s) is/are necessary.

4.1 Safety nut (wear indicator)

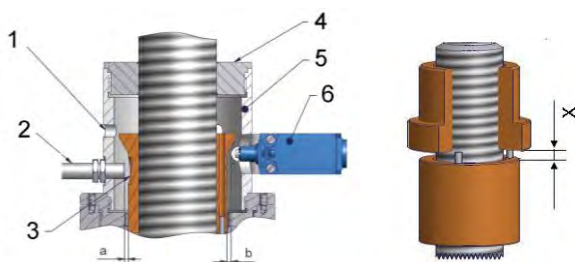

Principle: With increasing wear, the gap X reduces (documentation see 7.2.2)

Once the wear limit has been reached, the safety limit switch is activated. The switch signals need to be processed by the controller according to the requirements of the respective product standards.

Only possible with trapezoidal thread screws or buttress thread screws.

- 1 Visual wear indicator
- 2 Inductive transmitter
- 3 Pulse recession
- 4 Guide ring
- 5 Tube cap
- 6 Nut breakage limit switch

4.2 Safety-trap nut (optional with Ku screws)



If the Ku nut malfunctions, the Ku screw sets onto the thread of the trap nut. As a result, the power requirement of the drive motors is increased. The unit needs to be switched off by the controller or otherwise by a load monitor.

4.3 Options for screw jacks Ba1 and Ba2

4.3.1 Protection against skimming "Se", "Ve";



The end stop is a safety device and should not be used as a "working stop". If the end stop is run against the block, this can cause damages to the screw or gears.

4.3.2 Ball thread spindle "Ku"



Please note during assembly and transport. Ball thread spindles are not self-locking. Driving only permitted with a brake motor.

4.3.3 Multi-geared trapezoidal thread screws



Please note during assembly and transport. Multi-geared trapezoidal screw are not self-locking. Driving only permitted with a brake motor.

4.3.4 Buttress thread screws "S"



Only in combination with 2 guide rings.

5 Assembly

- Inspecting the used screw jacks for compliance with the technical requirements.
- Add-on construction, supporting structure and groundwork is designed for the maximum forces.
- Screw torques, see 5.9.3
- Protect screws from soiling during transport, assembly, construction and storage.
- Screws need to be protected during operation against soiling, e.g. by bellows, coils or on-site covers.
- On worm gear screw jacks with oil lubrication, check the oil level, refill if necessary, insert bleed plug, pull pin at bleed plug.
- If necessary, mount and set limit switch.
- Distortions increase power consumption and reduce the service life!
- Avoid misalignment and angular offset.
- Provide movable load support points if necessary.
- Unit risk analysis by the manufacturer of the overall system.

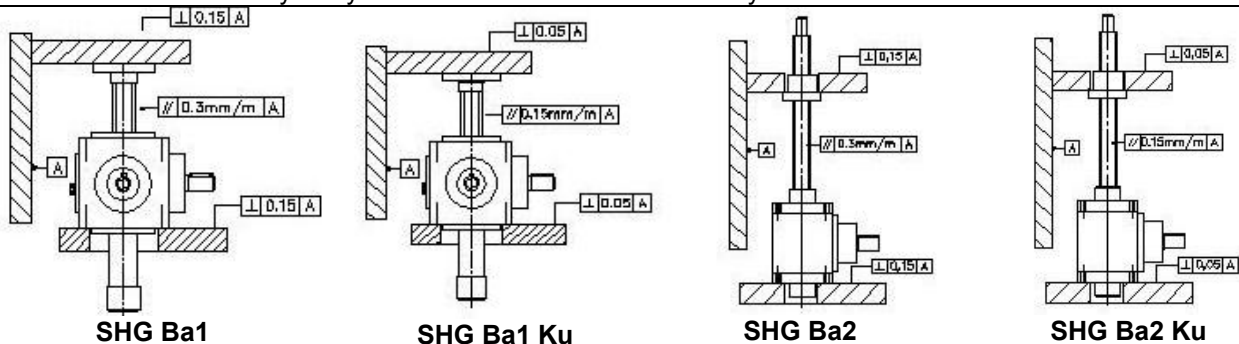

1. Align screw and screw jack with a spirit level and then screw tight, dowel down if necessary.
2. Make sure the screw is parallel and at a right angle to the on-site guides.
3. Avoid distortions. The worm shaft should turn easily and evenly throughout the entire lift height.
4. Clean screw and grease along the entire lift height.
5. Replace lock screw with oil sight glass (oil level indicator), pull tapered pin at the venting or insert pressure venting screw.
Check lubricant level and refill if necessary.

For multi-screw units



1. Check turning directions of all screw jacks.
2. Even out uneven support surfaces (pieces of sheet metal).
3. Move the screws/travelling nuts to the same height before depositing, aligning and fastening the load.



To even out alignment errors between the individual elements, use rotationally elastic couplings, rotationally elastic propeller shafts or cardan shafts.

5.1 Mounting positions

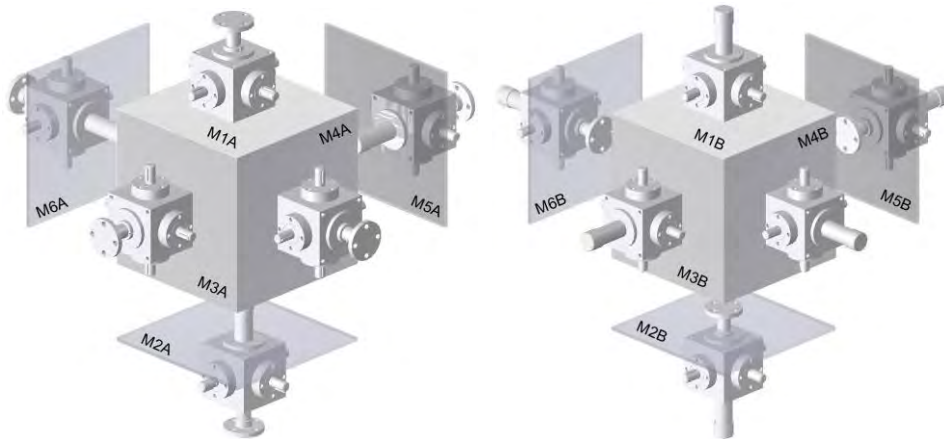

5.1.1 Shaft directions and oil fittings

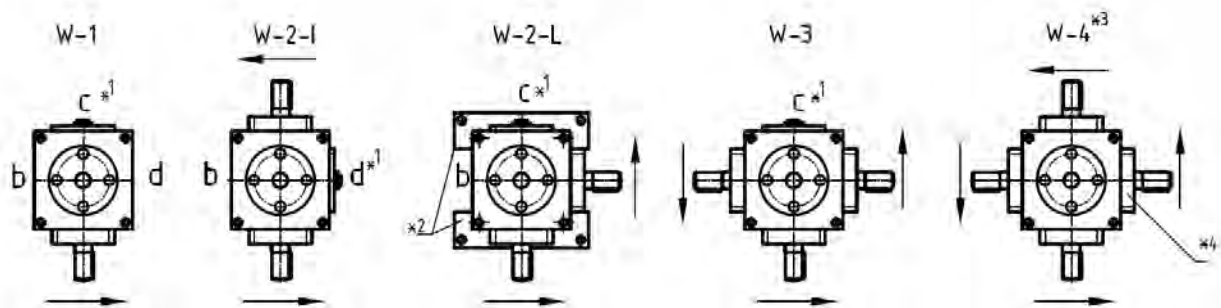

- = Rotating direction
- *1 = Position of oil sight glass
- *2 = Fastening bars (for G25 only)
- *3 = Without oil sight glass
- *4 = Position oil drain plug and filler plug



Screw the ventilation screw always on the highest position.

5.2 Assembly of the inductive limit switches

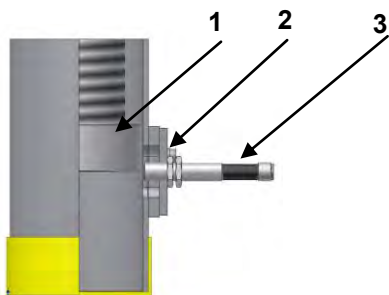

- 1 Switching cam
- 2 Counter nut
- 3 Inductive transmitter
- 4 Sensor fittings

1. Screw in the displacement sensor until it is aligned with the inner diameter of the tube wall thickness.
2. Secure the sensor emitter by tightening the hexagon nut and ensure that the emitter does not turn or the position is otherwise changed.



Should the sensor extend inwards, it will break and its sheared off parts have to be removed from the gears. Observe the maximum tightening torque!

Material	Type	Maximum tightening torque [Nm]
Plastic	M 8	0,25
	M 12	1,2
	M 18	2
Metal	M 8	2,5
	M 12	7
	M 18	35



4

Adjusting the switch point:

Loosen screws (4).
Slide the holding plate up or down
Tighten screws. Observe the tightening torques!

5.3 Assembly of electromechanical limit switches

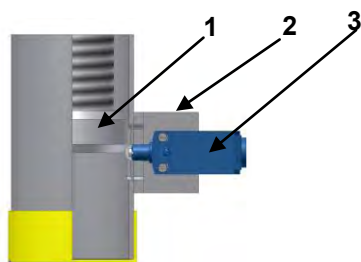

- 1 Switching cam
- 2 Holding plate
- 3 Mechanical limit switch
- 4 Limit switch fittings

1. Screw the limit switch onto the holding plate.
2. Carry out the lift test and set the actual lift.
Individual adjustments $\pm x$ according to the order confirmation / drawing.



Secure screws against unintentional loosening.



4

Adjusting the switch point:

Loosen screws (4).
Slide the holding plate up or down to the desired position.
Retighten the screws. Observe the tightening torques!

5.4 Assembly of safety nut

Pay attention to the installation position and force directions (pull/push)
The safety nut has to be placed subsequently in the load direction of the travelling nut.

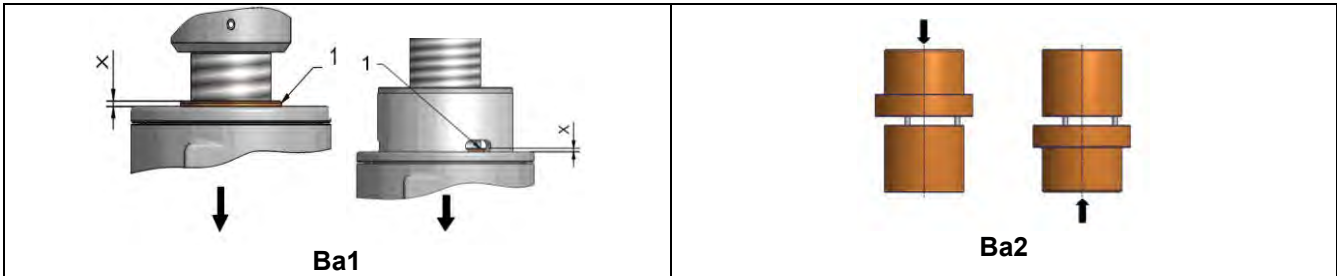

1 Wear indication ring
 = Load direction

5.5 Installing the nut breakage limit switch

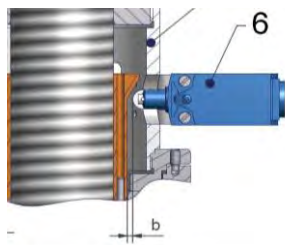

1. Screw the limit switch (6) onto the bracket; tighten screws only slightly. Push the switch all the way in until the roll rests against the safety nut.
2. Measure limit switch distance (for example, the back edge of the switch housing).
3. Pull the limit switch back by the distance b and tighten it.



Secure screws against unintentional loosening. Observe the tightening torques!

5.6 Installing the pulse generator (rotational speed monitor)

5.6.1 Pulse by cam

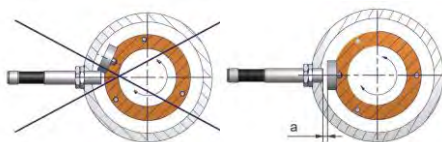

1. Turn the worm wheel (worm) until the pulse cam is visible in the fixing thread of the pulse generator.
2. Screw in the sensor until it contacts the outer diameter of the pulse cam.
3. Turn the transmitter back again by 0.5 to 1 rotation until the distance between the transmitter and the pin is between 0.5 and 1 mm (measurement a).
4. Tighten the hexagon nut to fasten the pulse generator. When doing this, ensure that the pulse generator does not turn!

5.6.2 Pulse by recession or flattening

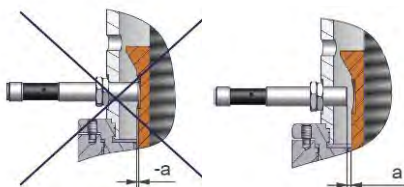

1. Turn the worm wheel (worm) until the pulse levelling is **not** visible in the fixing thread of the pulse generator.
2. Screw in the pulse transmitter until it lies at the **outer diameter** of the safety nut.
3. Turn the transmitter back again by 0.5 to 1 rotation until the distance between the transmitter and the safety nut is between 0.5 and 1 mm (dimension a).
4. Tighten the hexagon nut to fasten the pulse generator. When doing this, ensure that the pulse generator does not turn!



Should the sensor extend inwards, it will break and its sheared off parts have to be removed from the gears.
Observe the maximum tightening torque!

5.7 Mechanical fastening

5.7.1 Gear housing

Size SHG	G15	G25	G50	G90
Screws (Grade min. 8.8)	M 10	M12	M 12	M 20
Screws for head type II	M 10	M12	M 12	M 20
Number of screws	4	4	4	4

5.7.2 Screw heads

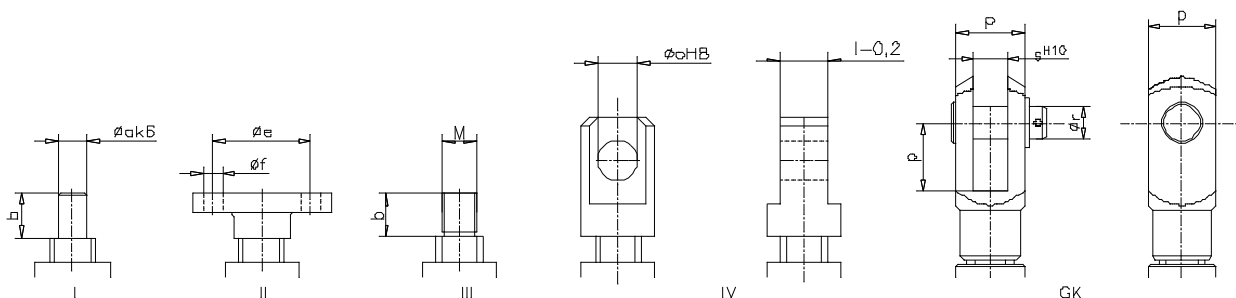

Size	G15	G25	G50	G90
$\varnothing a_{k6}$	-	20	-	-
$\varnothing e$	67	75	85	130
$n \times \varnothing f$	4 x $\varnothing 11$	4 x $\varnothing 14$	4 x $\varnothing 13$	4 x $\varnothing 21$
Thread	M18	M22x1,5	M30	M48x2
$\varnothing o_{H8}$	-	25	35	40
l	-	30 _{-0,2}	42	60 _{H10}
p	40	-	60	-
$\varnothing r$	20	-	30	-
s_{H10}	20	-	30	-
Screws for housing M x depth	M10 x 16	M 12 x 20	M12 x 25	M20 x 35



For the exact mounting dimensions, please request our dimensional drawings.

5.7.2.1 Joint heads



Screw jacks with joint heads are available as special models.

When using joint bearings or joint heads, a torsional lock needs to be installed on the gear side.

5.7.3 Screw tightening torques

Coarse-pitch thread	Tightening torque M _A [Nm]		
	Quality 8.8	Coarse-pitch thread	Quality 8.8
M 4	2,8	M 4	2,8
M 6	9,5	M 6	9,5
M 8	23	M 8	23
M 10	46	M 10	46
M 12	79	M 12	79
M 16	195	M 16	195
M 20	390	M 20	390
M 24	670	M 24	670
M 27	1000	M 27	1000
M 30	1350	M 30	1350
M 36	2330	M 36	2330
M 42	3676	M 42	3676
M 45	5502	M 45	5502
M 48	5636	M 48	5636
M 56	8856	M 56	8856

6 Initial operation



- Always observe and follow these operating instructions when using the equipment.
- Any use other than the intended use is prohibited.
- Commissioning may only be performed by authorised personnel.
- Check lubrication level.
- Check limit switches.
- Pay attention to the proper polarization of the electrical installation the the motor's sense of direction.
- Put lift unit into operation without a load. (1x lifting 1x lower)
- Operate intermittently, gradually increasing the load.
- During initial operation, constantly control the operating temperature, the motor's current consumption and the spindle contact pattern.
- After 5 hours of operation, check that the screws are tight. Retighten where necessary.
- Monitor the lubrication film and the screw temperature during the run-in phase. Rapid lubrication consumption and excessive temperature indicate undue lateral forces even if the power-on time and the maximum power specifications are complied with.

7 Maintenance and inspection

	The regular (recommendation 1 time per year) inspection/ maintenance is to be conducted by and authorised person (pursuant TRBS 1203) ³ on orders of the operator. All tests and modifications must be documented (e.g. machine file, inspection log).
	Power must be turned off before maintenance and inspection of the unit.
	Observe to the pertinent safety regulations during maintenance and inspection. Support loads.

³ We recommend that Pfaff-silberblau Hebezeugfabrik performs this inspection.

7.1 Maintenance plans

Scrw jack	Every 50 hours of operation**	Every 300 hours of operation or annually	Every 5 years or after 1000 hours of operation
 SHG Ba1	Check the screw's grease level and refill if necessary.	Safety test Grease the screw Check the gear lubrication level and refill if necessary. Damaged surface treatment should be properly repaired immediately. Grease the torsional lock.	Gear box oil change
 SHG Ba2			

** For special operating conditions, the lubrication intervals can be coordinated with us.

7.2 Maintenance instructions

7.2.1 Wear limits

Spindel	Tr 24x5	Tr 35x8	Tr 40x7	Tr 60x9
Max. Verschleiß [mm]	1,3	2	1,6	2,3

Verschleißgrenze von Sondergewinde auf Anfrage bzw. in auftragsbezogener Betriebsanleitung.

7.2.2 Quick lifting bevel gear screw jack with trapezoidal thread screw

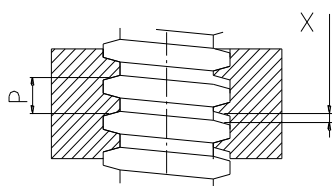

Safety test:

The wear of the nut thread in the worm wheel / in the travelling nut needs to be checked regularly, at least once per year.

Replacement is urgently required once the wear limit has been reached.

X = maximum wear

7.2.3 Quick lifting bevel gear screw jack with ball screw

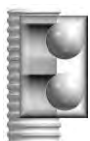

Safety test:

Pay attention to the running noises of the Ku screws during operation. An increase in noise indicates wear of the Ku nuts. The nuts and screws need to be replaced promptly.

The Ku screws/nuts should generally be exchanged at the end of its service life.

7.2.4 Safety screw jacks



For utilisation in systems according to EN 280, EN1570, EN1593; DIN 56950

In accordance with BetrSichV, lifting equipment must undergo an examination by an authorised person in intervals (at least 1x per year) specified by the owner (TRBS 1203).⁴

7.2.5 Screw jacks with safety nut

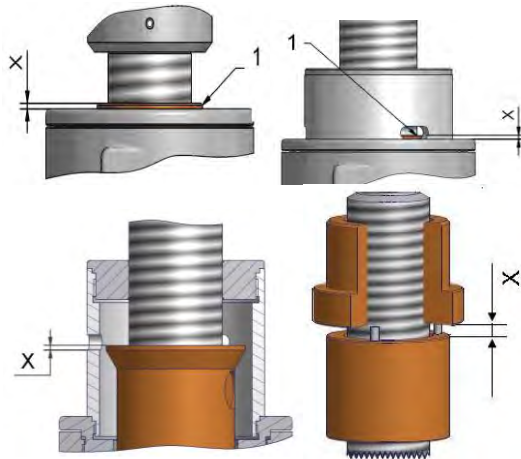

Safety test:

Check the wear in the screw jacks (dimension x) of the translation thread in the worm wheel / travelling nut. Prompt replacement of the carry nut and safety nuts is required should the safety nut (wear indication ring) align with the upper and lower edge of the housing or the wear limit has been reached (dimension X).

Wear limit = X - max. wear

1 = Wear indication ring

7.2.6 Record for measuring the wear

We recommend recording the new condition and the results from measuring the wear (dimension X).

	Screw jack 1	Screw jack 2	Screw jack. 3	Screw jack 4	Signature
New condition Dimension X					
Measuring the wear on _____					
Measuring the wear on _____					
Measuring the wear on _____					
Measuring the wear on _____					

7.3 Lubrication

Suitable for ambient temperature -10 bis +40°C

If temperatures deviate, a design by our technical office is necessary..

7.3.1 Lubricants

Size	Gear lubricant Ex-Works	Tr-Screw lubricant	Ball screw lubricant
G 15	CLP PG 220	Formax 60 or Ps Grease 011 or Klüberplex GE 11 680	Klüber Stabutherm GH-461 or Formax 50
G 25	CLP 220		
G 50	CLP PG 220		
G 90	CLP PG 220		

⁴ We recommend that Pfaff-silberblau Hebezeugfabrik performs this inspection.

7.3.2 Spindle lubrication



Clean the screw with grease evenly with a brush.

We recommend an automatic lubricant dispenser in places of difficult accessibility, a longer power time or in dirty environments.

7.3.3 Gear unit lubrication

Oil level, location of the oil sight glasses, venting and drain screw, refer to Chapter 5.1 Mounting positions.

7.3.4 Grease the torsional lock (V)



Lubricate the lubrication nipple (2) at the guiding tube with the grease gun. Grease amount about 20 ml at 500 mm lift height.

7.3.5 Quantities of lubricant

Size SHG	G15	G25	G50	G90
Oil Quantity approx. (l)	0,15	0,9	0,6	3,5

8 Decommissioning



When decommissioning the system, recycle or dispose of the various system components and/or screw jacks according to the legal requirements.

<p>Einbauerklärung für unvollständige Maschinen im Sinne der EG-Maschinen- richtlinie 2006/42/EG, Anhang II, Nr. 1B</p>	<p>Declaration of incorporation for incomplete machines according to EC machine directive 2006/42/EC, Annex II, No. 1B</p>	<p>Déclaration d'incorporation pour machines incomplètes conformément à la directive européenne relative aux machines 2006/42/CE, annexe II, n° 1B</p>
<p>Schnellhubgetriebe SHG Bauart 1 und 2 Antriebselement zum Einbau in eine Maschine</p>	<p>Worm Gear Screw Jack SHG type 1 and 2 Actuator element for assembly in a machine</p>	<p>Vérins à vis sans fin SHG type 1 et type 2 Propulsife élément pour assemblée dans une machine</p>
<p>ist eine unvollständige Maschine nach Artikel 2g und ausschließlich zum Einbau in eine Maschine oder zum Zusammenbau mit anderen Maschinen oder Ausrüstung vorgesehen.</p>	<p>is an incomplete machine according to Article 2 g and has been designed exclusively for installation in a machine or for assembly with other machines or equipment.</p>	<p>est une machine incomplète selon l'article 2g et a été conçue uniquement pour être montée dans une machine ou à être assemblée avec d'autres machines ou équipement.</p>
<p>Folgende grundlegenden Sicherheits- und Gesundheitsschutzanforderungen gemäß Anhang I dieser Richtlinie kommen zur Anwendung und wurden eingehalten 1.1.2; 1.1.3; 1.1.5; 1.3.2; 1.3.3; 1.3.4; 1.3.7; 1.3.9; 1.5.2; 1.7.3; 1.7.4; 4.1.2.6</p>	<p>The following basic health and safety requirements in Annex I to this Directive are applicable and have been observed 1.1.2; 1.1.3; 1.1.5; 1.3.2; 1.3.3; 1.3.4; 1.3.7; 1.3.9; 1.5.2; 1.7.3; 1.7.4; 4.1.2.6</p>	<p>Les exigences suivantes de sécurité et relatives à la santé, conformes à l'annexe I de cette directive, ont été appliquées et respectées 1.1.2; 1.1.3; 1.1.5; 1.3.2; 1.3.3; 1.3.4; 1.3.7; 1.3.9; 1.5.2; 1.7.3; 1.7.4; 4.1.2.6</p>
<p>Die speziellen technischen Unterlagen gemäß Anhang VII B wurden erstellt und sie werden der zuständigen nationalen Behörde auf Verlangen in elektronischer Form übermittelt</p>	<p>The special technical documentation referred to in Annex VII B has been prepared and will be forwarded to the competent national authority, upon request in electronic form</p>	<p>La documentation technique spéciale conforme à l'annexe VII B a été préparée et sera transmise aux autorités nationales compétentes, également sous forme électronique, si nécessaire.</p>
<p>Diese unvollständige Maschine ist in Übereinstimmung mit den Bestimmungen der folgenden EG Richtlinien</p>	<p>This incomplete machine is in compliance with the provisions of the following EC directives</p>	<p>Cette machine incomplète est conforme aux dispositions des directives européennes suivantes</p>
<p>Angewendete harmonisierte Normen, insbesondere: EN 1494:2000+A12008; EN ISO 12100:2010</p>	<p>Applied harmonised standards, in particular: EN 1494:2000+A12008; EN ISO 12100:2010</p>	<p>Normes harmonisées utilisées, en particulier :</p>
<p>Angewendete nationale Normen und technische Spezifikationen, insbesondere:</p>	<p>Applied national technical standards and specifications, in particular:</p>	<p>Normes et spécifications techniques nationales qui ont été utilisées, notamment</p>
<p>Diese unvollständige Maschine darf erst dann in Betrieb genommen werden, wenn festgestellt wurde, dass die Maschine, in die diese unvollständige Maschine eingebaut werden soll, den Bestimmungen der EG-Maschinenrichtlinie entspricht</p>	<p>This incomplete machine may only be put into operation if it has been determined that the machine into which this incomplete machine will be installed complies with the provisions of the EC machine directive</p>	<p>Cette machine incomplète ne doit être mise en service que lorsqu'il a été déterminé, que la machine dans laquelle cette machine incomplète doit être montée, est conforme aux dispositions de la directive européenne relative aux machines</p>

Kissing, 01.04.2011

Name

Columbus McKinnon Engineered Products GmbH
 Am Silberpark 2-8, 86438 Kissing, Germany
 www.silberblau.com
 ppa. Ulrich Hintermeier, Leiter Technik und Vertrieb / Director Engineering and Sales
 Konrad Ertl, Leiter Forschung und Entwicklung / Head of Research and Development

<p>Der Unterzeichnende ist bevollmächtigt die technischen Unterlagen gemäß Anhang VII A zusammenzustellen und der zuständigen Behörde auf Verlangen zu übermitteln.</p>	<p>The undersigned is authorised to prepare the technical documentation referred to in Annex VII A and submit it to the responsible authorities on request.</p>	<p>Le signataire est habilité à réunir la documentation technique spéciale conforme à l'annexe VII A et à la transmettre aux autorités compétentes si nécessaire.</p>
---	---	---

<p>Einbauerklärung für unvollständige Maschinen im Sinne der EG-Maschinen- richtlinie 2006/42/EG, Anhang II, Nr. 1B</p>	<p>Declaration of incorporation for incomplete machines according to EC machine directive 2006/42/EC, Annex II, No. 1B</p>	<p>Déclaration d'incorporation pour machines incomplètes conformément à la directive européenne relative aux machines 2006/42/CE, annexe II, n 1B</p>
<p>Schnellhubgetriebe SHG Bauart 1 und 2 mit Sicherheitseinrichtungen Antriebsselement zum Einbau in Hubtische, Hebebühnen, Hubarbeitsbühnen oder Fahrzeugehebühnen</p>	<p>Worm Gear Screw Jack SHG type 1 and 2 with safety devices Actuator element for for assembly in lifting tables, lifting platforms, working platforms or vehicle lifting platforms</p>	<p>Vérins à vis sans fin SHG type 1 et type 2 avec équipement de sûreté Propulsife élément pour installation dans table de levage, plateforme élevatrice, plateforme de travaille, plateforme de levage pour véhicule</p>
<p>ist eine unvollständige Maschine nach Artikel 2g und ausschließlich zum Einbau in eine Maschine oder zum Zusammenbau mit anderen Maschinen oder Ausrüstung vorgesehen.</p>	<p>is an incomplete machine according to Article 2 g and has been designed exclusively for installation in a machine or for assembly with other machines or equipment.</p>	<p>est une machine incomplète selon l'article 2g et a été conçue uniquement pour être montée dans une machine ou à être assemblée avec d'autres machines ou équipement.</p>
<p>Folgende grundlegenden Sicherheits- und Gesundheitsschutzanforderungen gemäß Anhang I dieser Richtlinie kommen zur Anwendung und wurden eingehalten 1.1.2; 1.1.3; 1.1.5; 1.3.2; 1.3.3; 1.3.4; 1.3.7; 1.3.9; 1.5.2; 1.7.3; 1.7.4; 4.1.2.6</p>	<p>The following basic health and safety requirements in Annex I to this Directive are applicable and have been observed 1.1.2; 1.1.3; 1.1.5; 1.3.2; 1.3.3; 1.3.4; 1.3.7; 1.3.9; 1.5.2; 1.7.3; 1.7.4; 4.1.2.6</p>	<p>Les exigences suivantes de sécurité et relatives à la santé, conformes à l'annexe I de cette directive, ont été appliquées et respectées 1.1.2; 1.1.3; 1.1.5; 1.3.2; 1.3.3; 1.3.4; 1.3.7; 1.3.9; 1.5.2; 1.7.3; 1.7.4; 4.1.2.6</p>
<p>Die speziellen technischen Unterlagen gemäß Anhang VII B wurden erstellt und sie werden der zuständigen nationalen Behörde auf Verlangen in elektronischer Form übermittelt</p>	<p>The special technical documentation referred to in Annex VII B has been prepared and will be forwarded to the competent national authority, upon request in electronic form</p>	<p>La documentation technique spéciale conforme à l'annexe VII B a été préparée et sera transmise aux autorités nationales compétentes, également sous forme électronique, si nécessaire.</p>
<p>Diese unvollständige Maschine ist in Übereinstimmung mit den Bestimmungen der folgenden EG Richtlinien</p>	<p>This incomplete machine is in compliance with the provisions of the following EC directives</p>	<p>Cette machine incomplète est conforme aux dispositions des directives européennes suivantes</p>
<p>Angewendete harmonisierte Normen, insbesondere: EN 1494:2000+A12008; EN ISO 12100:2010 EN1570; EN280; EN1756; EN1493</p>	<p>Applied harmonised standards, in particular:</p>	<p>Normes harmonisées utilisées, en particulier :</p>
<p>Angewendete nationale Normen und technische Spezifikationen, insbesondere:</p>	<p>Applied national technical standards and specifications, in particular:</p>	<p>Normes et spécifications techniques nationales qui ont été utilisées, notamment</p>
<p>Diese unvollständige Maschine darf erst dann in Betrieb genommen werden, wenn festgestellt wurde, dass die Maschine, in die diese unvollständige Maschine eingebaut werden soll, den Bestimmungen der EG-Maschinenrichtlinie entspricht</p>	<p>This incomplete machine may only be put into operation if it has been determined that the machine into which this incomplete machine will be installed complies with the provisions of the EC machine directive</p>	<p>Cette machine incomplète ne doit être mise en service que lorsqu'il a été déterminé, que la machine dans laquelle cette machine incomplète doit être montée, est conforme aux dispositions de la directive européenne relative aux machines</p>

Kissing, 01.04.2011

Name

COLUMBUS McKINNON Engineered Products GmbH
ppa. Ulrich Hintermeier Silberpark 2-8, 86438 Kissing, Germany
Leitung Technik und Vertrieb
berblau.com
Leiter Forschung und Entwicklung
Head of Research and Development

<p>Der Unterzeichnende ist bevollmächtigt die technischen Unterlagen gemäß Anhang VII A zusammenzustellen und der zuständigen Behörde auf Verlangen zu übermitteln.</p>	<p>The undersigned is authorised to prepare the technical documentation referred to in Annex VII A and submit it to the responsible authorities on request.</p>	<p>Le signataire est habilité à réunir la documentation technique spéciale conforme à l'annexe VII A et à la transmettre aux autorités compétentes si nécessaire.</p>
---	---	---